



**SPECIFICATIONS**

- CONTACT RATING:** Dependent upon contact material.
- MECHANICAL LIFE:** 30,000 make-and-break cycles.
- CONTACT RESISTANCE:** 20mΩ max. initial @ 2-4VDC  
100mA for both silver and gold plated contacts.
- INSULATION RESISTANCE:** 1,000MΩ min.
- DIELECTRIC STRENGTH:** 1,000 V RMS@sea level.
- OPERATING TEMPERATURE:** -30°C to 85°C.

**MATERIALS**

- CASE & BUSHING:** Class filled nylon 4/6, flame retardant, heat stabilized (UL94v-0).
- ACTUATOR:** Brass, chrome plated, internal O-ring seal.  
Standard for all actuators.
- SWITCH SUPPORT:** Brass, tin plated.
- CONTACT / TERMINALS:** Copper alloy, with Silver or gold plated.  
(See Page 40)

**HOW TO ORDER**

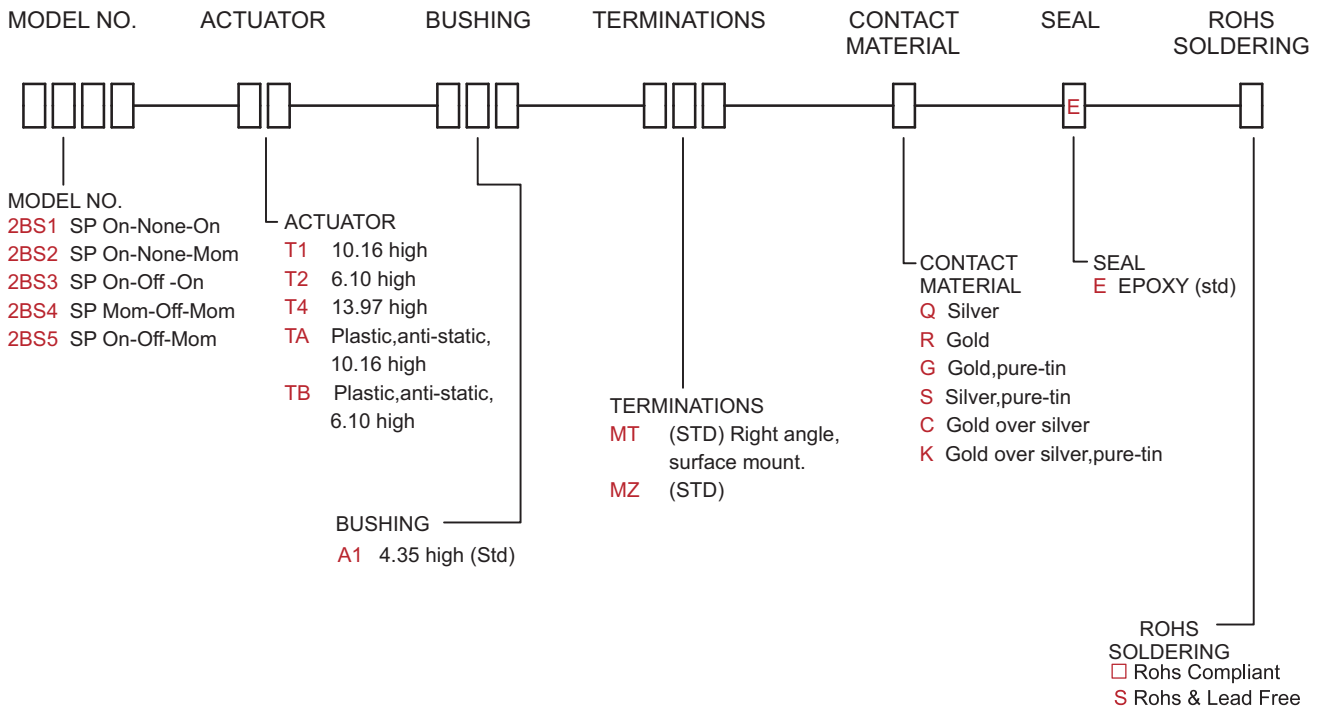

## SWITCH FUNCTION

NO. POLES	UL-CSA	MODEL NO.	SWITCH FUNCTION			CONNECTED TERMINALS / SCHEMATIC		
			POS.1	POS.2	POS.3	POS.1	POS.2	POS.3
SP	Q22B11	2BS1	ON	NONE	ON		N/A	
	Q22B12	2BS2	ON	NONE	MOM			
	Q22B13	2BS3	ON	OFF	ON			
	Q22B14	2BS4	MOM	OFF	MOM			
	Q22B15	2BS5	ON	OFF	MOM			

## POLE OPTIONS

### MT

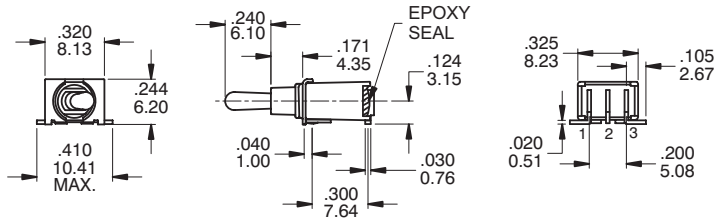

### P.C. MOUNTING

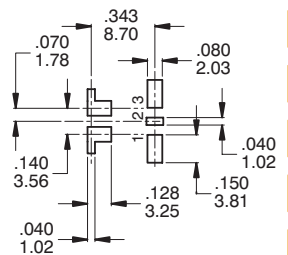

### SPDT

Part No. Shown : 2BS1T2A1MTRE

### MZ

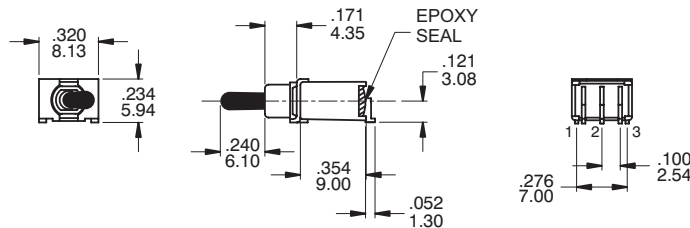

### P.C. MOUNTING

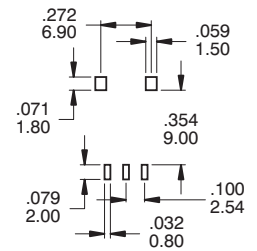

### SPDT

Part No. Shown : 2BS1TBA1MZRE

## ACTUATOR OPTIONS

### T1

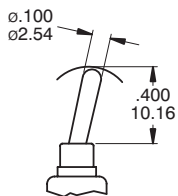

### T2

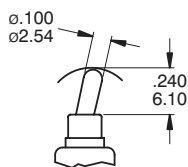

### TA

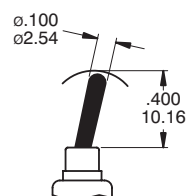

### TB

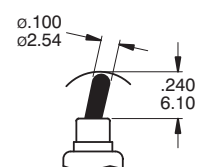

ESD  
PLASTIC ACTUATOR

**PACKAGING**

Switches available on embossed antistatic tape and reels.  
Tape and cover strip are conductive for use near statically sensitive components.

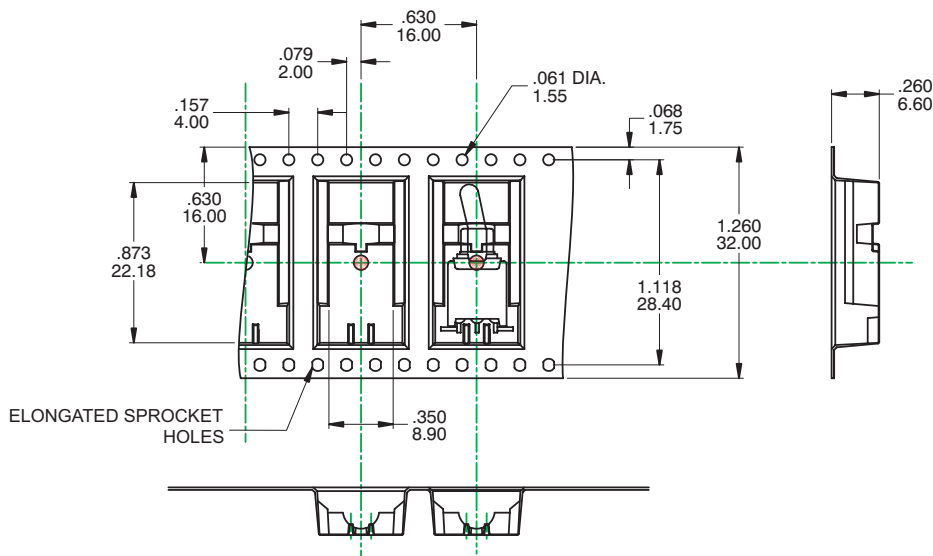
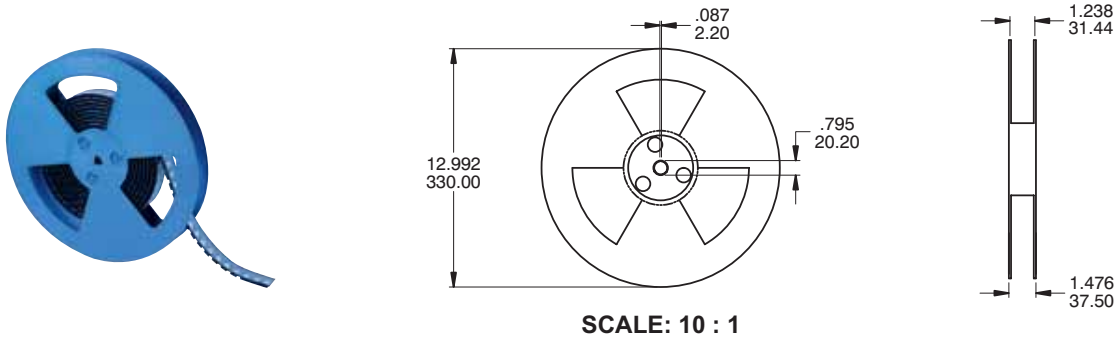

REEL INFORMATION	
QUANTITY PER REEL	500 / pcs

**CONTACT MATERIAL OPTIONS**

	CONTACT MATERIAL	TERMINAL PLATING	RATINGS
Q	Silver	Q = Gold flash over silver	3 Amps with resistant load @ 120VAC or 28VDC 1 Amps with resistant load @ 250VA
S		S = Gold flash over silver,pure - tin	
C	Gold over Silver	C = Gold over silver	
K		K = Gold over silver,pure - tin	
R	Gold	R = Gold	0.4 Volt - Amps ( VA ) max. @ 20V max. ( AC or DC )
G		G = Gold,pure - tin	



**IP 67**  
 ACCORDING TO  
 EN 60529:1991+A1:2001  
 IEC 60529:2001

**SOLDERING PROCESSES**

**WAVE SOLDERING :** Recommended Soldering Temperature :  $260 \pm 5^{\circ}\text{C}$   
 Duration of Solder Immersion :  $5 \pm 1$  seconds  
 (PCB is 1.6mm in thickness)

**SOLDERING :** Vapor phase & IR-reflow soldering can be applied.

