

Rotary Actuated Air Gripper

MHR2, MDHR2/MHR3, MDHR3

2-finger type

3-finger type

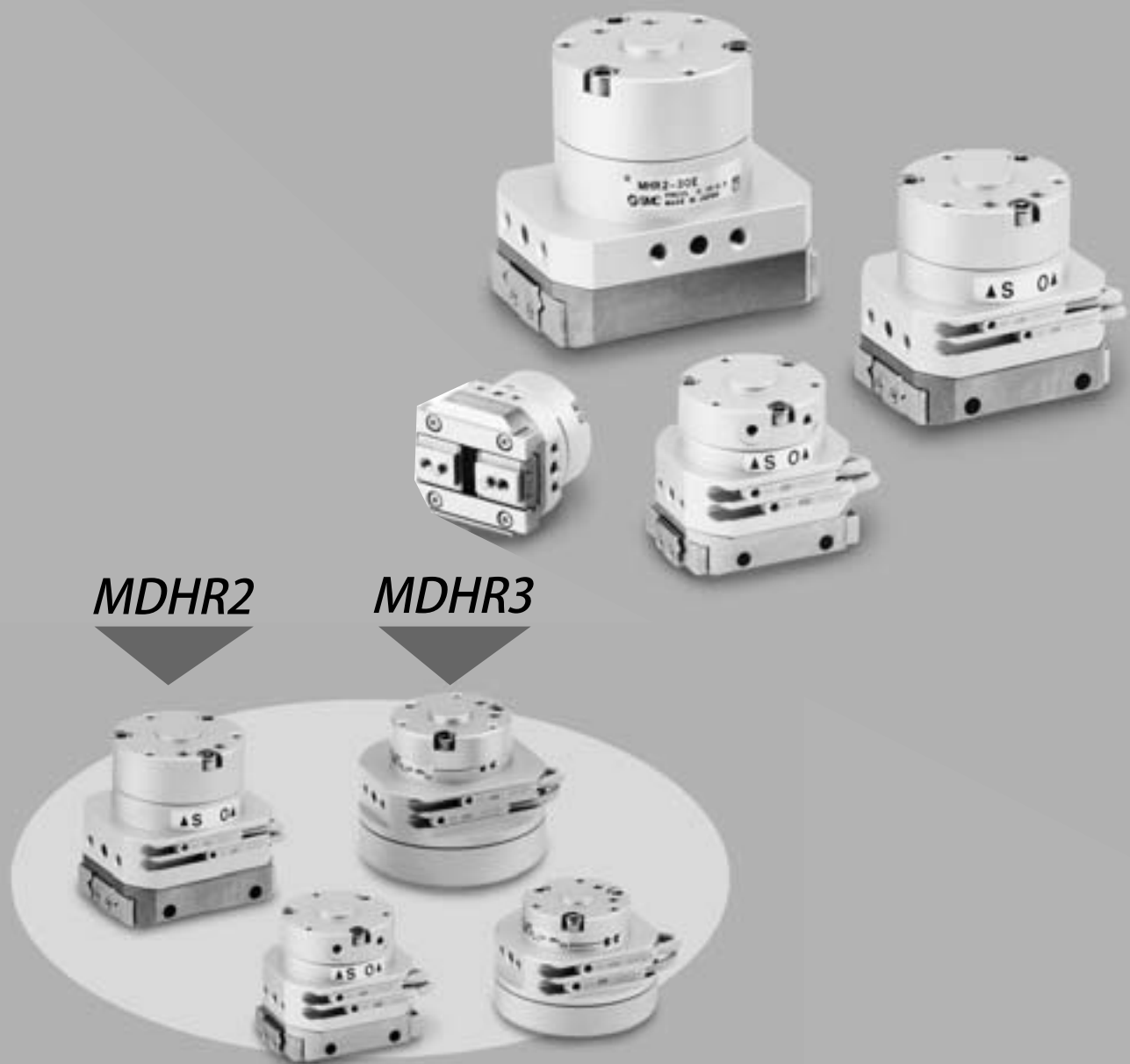

MDHR2

MDHR3

High rigidity

Fingers operate smoothly as the holder maintains the guide from the outside and prevents finger displacement.



Applicable for Clean Series.

Refer to "Pneumatic Clean Series" catalog for details.

Internal/External gripping capability

Connection port on 2 sides

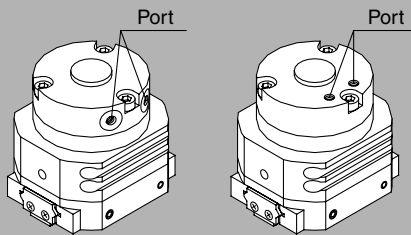

Series Variations

		(Nominal size)				Auto switch		
		10	15	20	30			
Rotary actuated air gripper	2-finger type	MHR2	●	●	●	●	P. 491 to P. 503	
		MDHR2	●	●	●	●		●
	3-finger type	MHR3	●	●			P. 504 to P. 511	
		MDHR3	●	●				●
Clean Series Rotary actuated air gripper	2-finger type	11-22-MHR2	●	●	●	●	Refer to the "Pneumatic Clean Series" catalog.	
		11-22-MDHR2	●	●	●	●		●
	3-finger type	11-22-MHR3	●	●				
		11-22-MDHR3	●	●				

Rotary Actuated Air Gripper/2-Finger Type

Series *MHR2/MDHR2*

Size: 10, 15, 20, 30

How to Order

Without auto switch

MHR 2 - 10 R - []

With auto switch
(Built-in magnet)

MDHR 2 - 10 R - M9N S - []

With magnet
(For auto switch)

Number of fingers
2 2 fingers

Nominal size
10
15
20
30

Connecting port

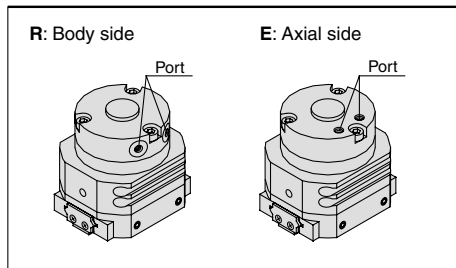

Made to Order
Refer to page 492 for details.

Number of auto switches

Nil	2 pcs.
S	1 pc.

Applicable Auto Switch Refer to pages 761 to 809 for further information on auto switches.

Type	Special function	Electrical entry	Indicator light	Wiring (Output)	Load voltage		Auto switch model		Lead wire length (m)*				Pre-wired connector	Applicable load		
					DC	AC	Electrical entry direction		0.5 (Nil)	1 (M)	3 (L)	5 (Z)		IC circuit	Relay, PLC	
							Perpendicular	In-line								
Solid state switch	—	Grommet	Yes	3-wire (NPN)	24V	5V, 12V	—	M9NV	M9N	●	●	●	○	○	—	
				3-wire (PNP)				M9PV	M9P	●	●	●	○			
				2-wire				M9BV	M9B	●	●	●	○			

* Lead wire length symbols: 0.5 m Nil (Example) M9N
1 m M (Example) M9NM
3 m L (Example) M9NL
5 m Z (Example) M9NZ

* Solid state auto switches marked with a "○" symbol are produced upon receipt of order.

MHZ

MHF

MHL

MHR

MHK

MHS

MHC

MHT

MHY

MHW

-X□

MRHQ

MA

D-□

Series MHR2/MDHR2



JIS Symbol

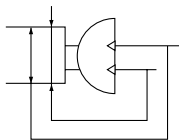

Model/Specifications

Nominal size		10	15	20	30
Action		Double acting			
Gripping force (N) ⁽¹⁾ (Effective value) at 0.5 MPa	External grip	12	24	33	58
	Internal grip	12	25	34	59
Opening/ Closing stroke (Both sides)	Finger closing width (mm)	10	14	16	19
	Finger opening width (mm)	16	22	28	37
	Stroke (mm)	6	8	12	18
Mass (g) ⁽²⁾		100 (95)	180 (175)	390 (380)	760 (740)
Connection port		M3 X 0.5		M5 X 0.8	
Repeatability		±0.01mm			
Fluid		Air			
Operating pressure		0.2 to 0.6 MPa	0.15 to 0.6 MPa		
Ambient and fluid temperature		0 to 60°C			
Max. operating frequency		180 c.p.m			
Lubrication		Non-lube			



Note 1) Refer to page 494 "Effective Gripping Force" for details of Gripping force at each gripping point. Value of effective gripping force is measured at the middle of opening/closing stroke.

Note 2) () Value shows MDHR mass, but it does not include auto switch mass.

When the finger opening/closing speed is set as the total stroke of 0.2 seconds or more, it may cause the product to stick or completely stop its movement.



Made to Order

(Refer to pages 683 to 713 for details.)

Symbol	Specifications/Description
-X32	Countermeasure for condensation
-X63	Fluorine grease

Gripping Point

- Workpiece gripping point should be within the gripping point range: The range shown for each operating pressure given in the graphs to the right.
- When the gripping point distance becomes large, the finger attachment applies an excessively large load to the finger sliding section, causing excessive play of the fingers and possibly leading to premature failure.

External grip

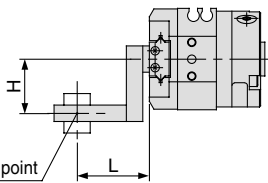
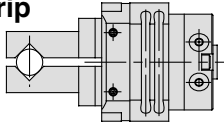

Gripping point

L: Distance to the gripping point
H: Overhang distance

Internal grip

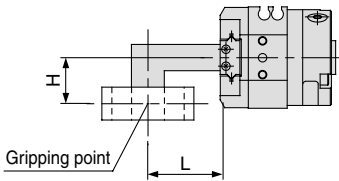
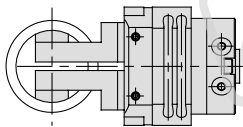

Gripping point

Limitation of Gripping: External Grip/Internal Grip

MHR2-10/MDHR2-10

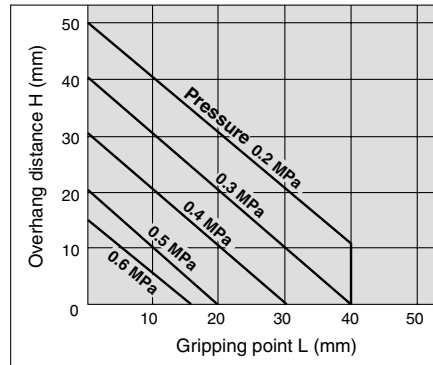

MHR2-20/MDHR2-20

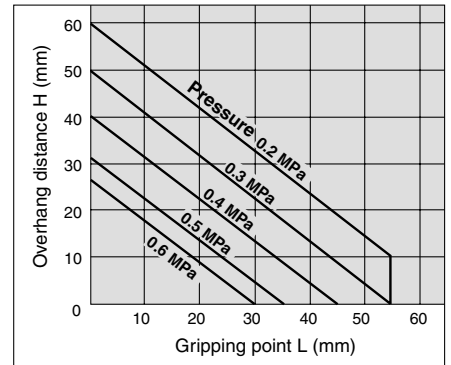

MHR2-15/MDHR2-15

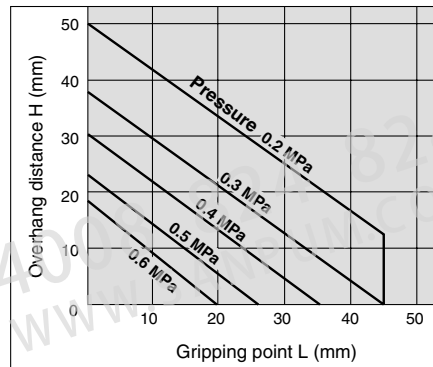

MHR2-30/MDHR2-30

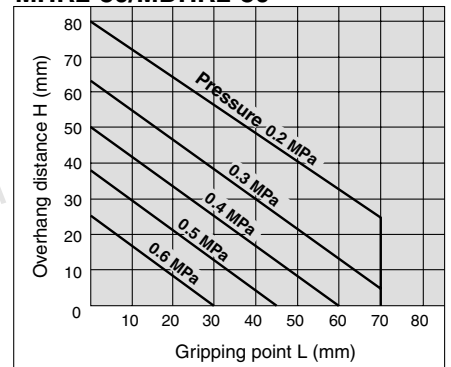

MHZ

MHF

MHL

MHR

MHK

MHS

MHC

MHT

MHY

MHW

-X□

MRHQ

MA

D-□

Series MHR2/MDHR2

Effective Gripping Force

Guidelines for the selection of the gripper with respect to component mass

- Although conditions differ according to the workpiece shape and the coefficient of friction between the attachments and the workpiece, select a model that can provide a gripping force of 10 to 20 times the workpiece mass, or more.
- If high acceleration, deceleration or impact forces are encountered during motion a further margin of safety should be considered.

External grip

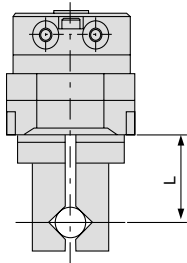

Internal grip

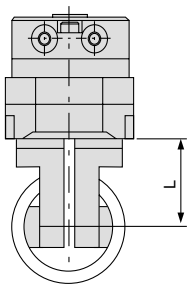

L: Gripping point length (mm)

• Indication of effective gripping force

The effective gripping force shown in the graphs to the right is expressed as F, which is the thrust of one finger, when both fingers and attachments are in full contact with the workpiece as shown in the figure below.

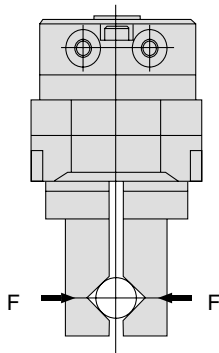

External Grip

MHR2-10/MDHR2-10

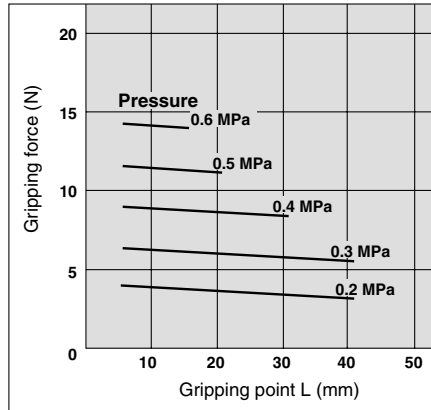

MHR2-15/MDHR2-15

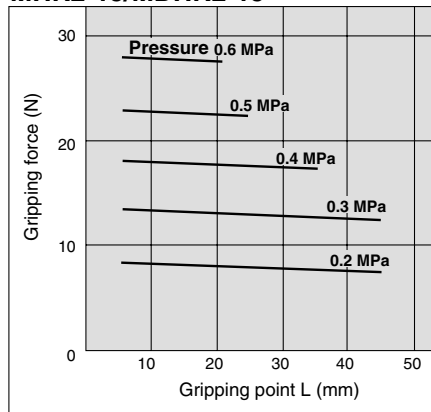

MHR2-20/MDHR2-20

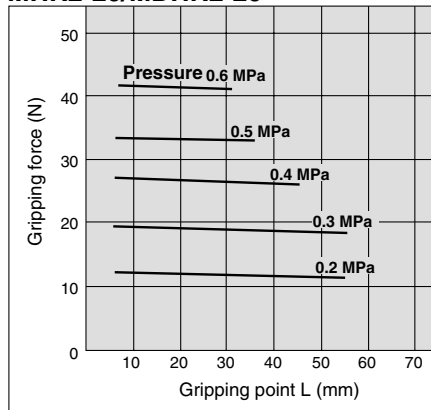

MHR2-30/MDHR2-30

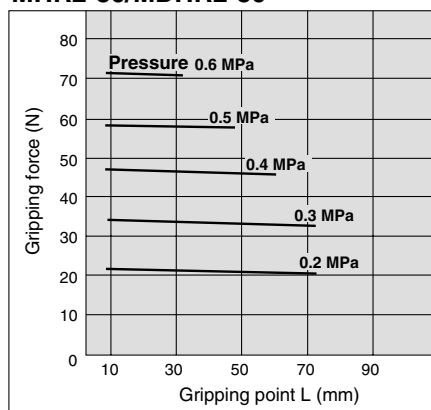

Internal Grip

MHR2-10/MDHR2-10

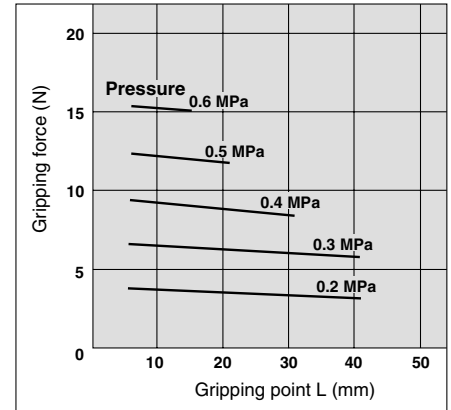

MHR2-15/MDHR2-15

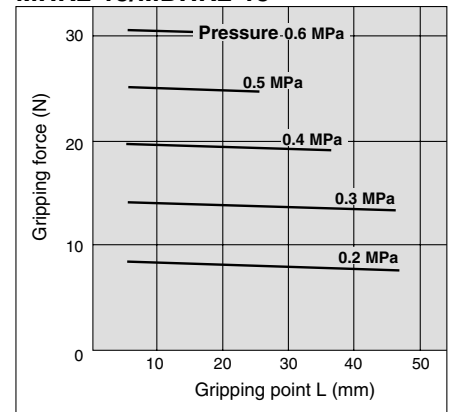

MHR2-20/MDHR2-20

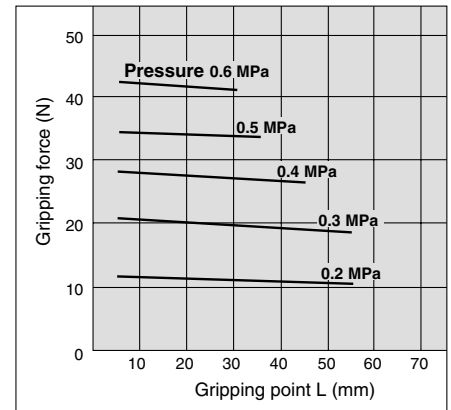

MHR2-30/MDHR2-30

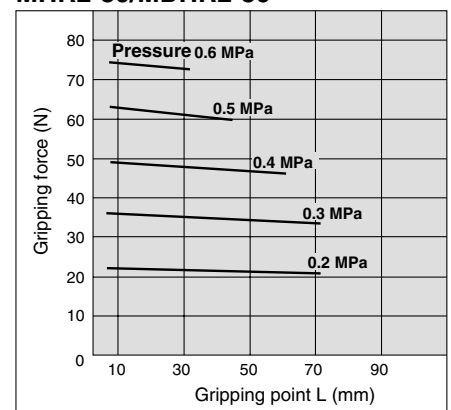

Construction

MHR2

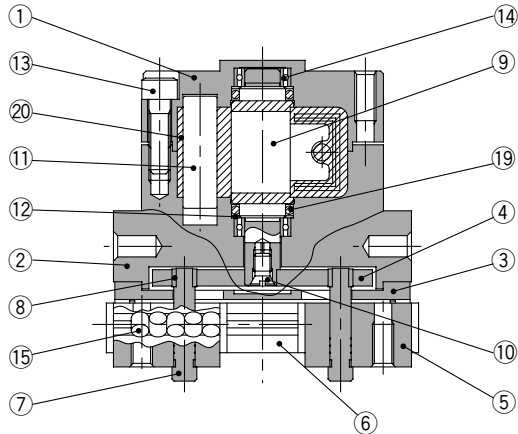

MDHR2

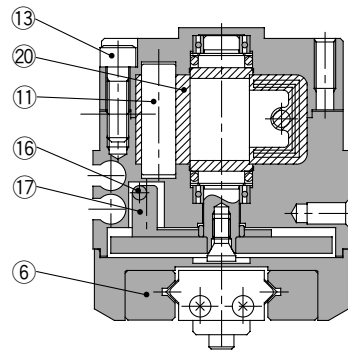
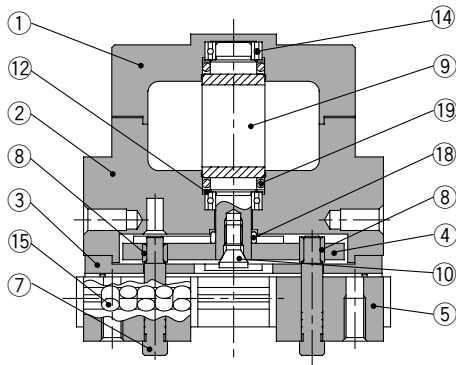

Component Parts

No.	Description	Material	Note
1	Body	Aluminum alloy	Hard anodized
2	Adaptor body	Aluminum alloy	Hard anodized
3	Guide holder	Stainless steel	
4	Cam	Cold rolled steel	Nitriding
5	Finger assembly	Stainless steel	Heat treated
6	Guide	Stainless steel	Heat treated
7	Pin	Carbon steel	Heat treated Electroless nickel plated
8	Pin roller	Stainless steel	Nitriding
9	Vane shaft	Stainless steel, NBR	M□HR2-30 is carbon steel NBR
10	Joint bolt	Chrome molybdenum steel	Zinc chromated

Component Parts

No.	Description	Material	Note
11	Stopper	Resin	
12	Back-up ring	Stainless steel plate	
13	Hexagon socket head bolt	Stainless steel	
14	Bearing	High carbon chrome bearing steel	
15	Cylindrical roller	—	
16	Magnet	Stainless steel	
17	Magnet holder	Aluminum alloy	Hard anodized
18	Roller	Stainless steel	
19	O-ring	NBR	
20	Stopper seal	NBR	

MHZ

MHF

MHL

MHR

MHK

MHS

MHC

MHT

MHY

MHW

-X□

MRHQ

MA

D-□

Series MHR2/MDHR2

Nominal Size 10

Without auto switch : MHR2-10R

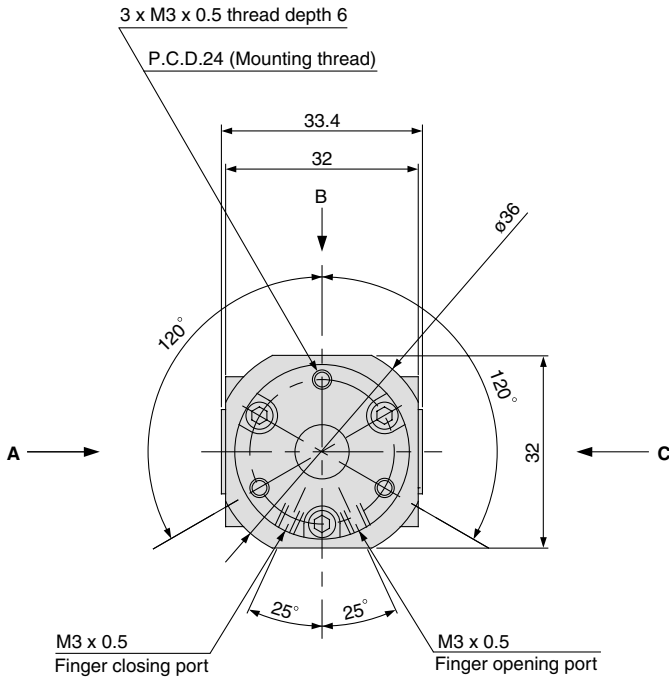

MHR2-10E Port Location

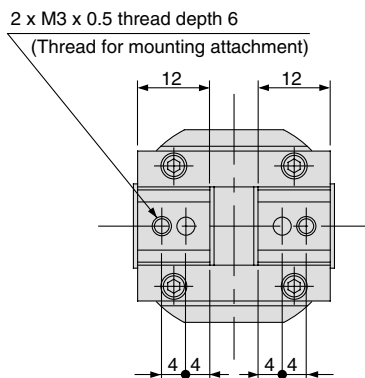
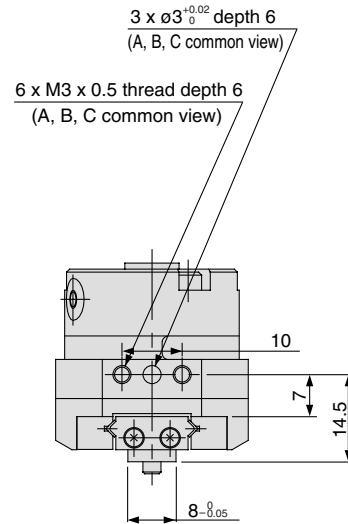
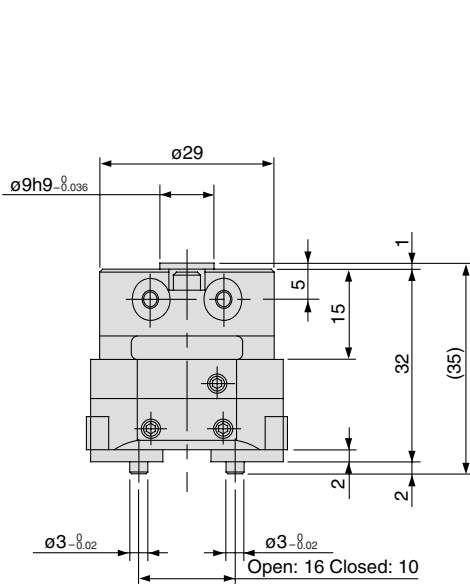
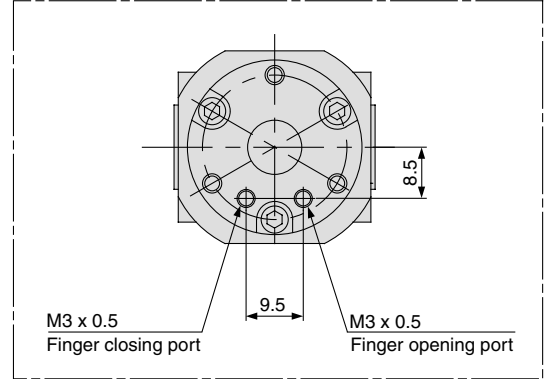

Rotary Actuated Air Gripper 2-Finger Type **Series MHR2/MDHR2**

With auto switch (Built-in magnet) : MDHR2-10R

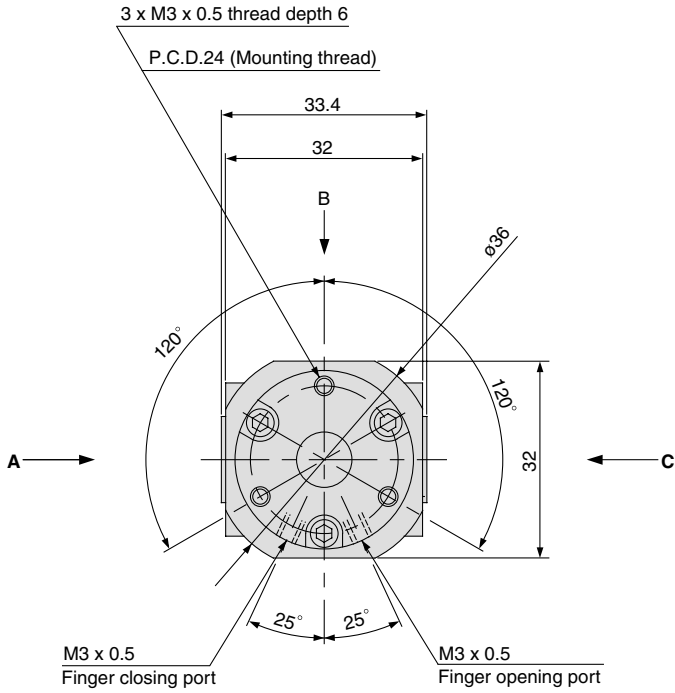

MDHR2-10E Port Location

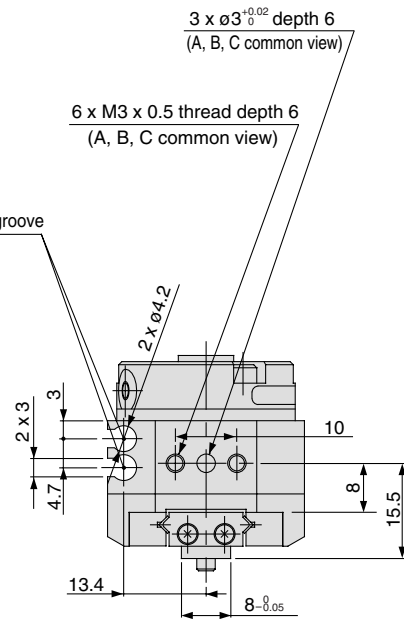
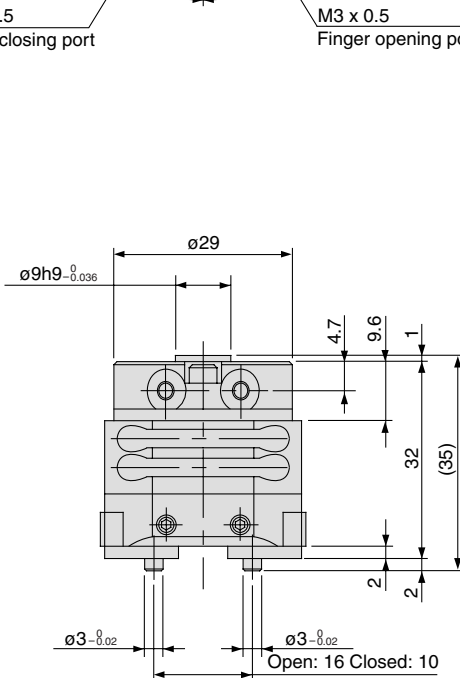
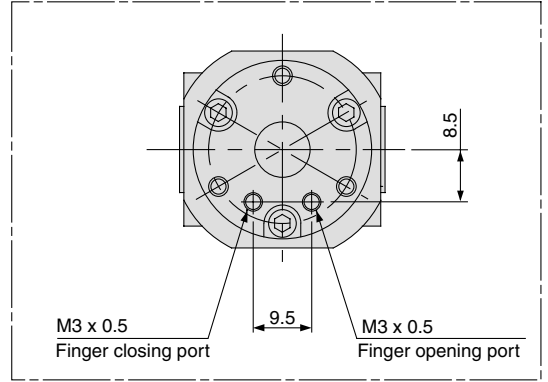

Dimensional Differences between MHR and MDHR

The following dimensions are different between series MHR and MDHR. And also, body shapes are different depending on auto switch mounting groove.

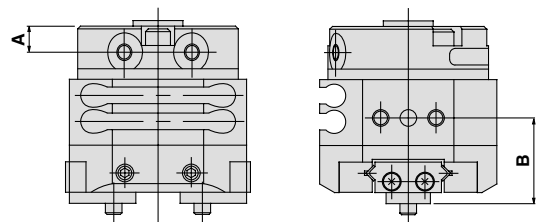

Model		A	B
MHR2	-10R	5	14.5
	-10E	—	14.5
MDHR2	-10R	4.7	15.5
	-10E	—	15.5

MHZ

MHF

MHL

MHR

MHK

MHS

MHC

MHT

MHY

MHW

-X□

MRHQ

MA

D-□

Series MHR2/MDHR2

Nominal Size 15

Without auto switch : MHR2-15R

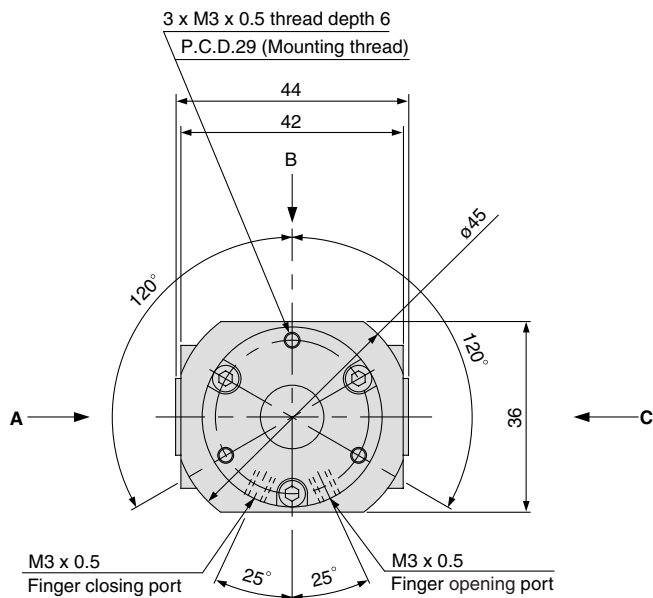

MHR2-15E Port Location

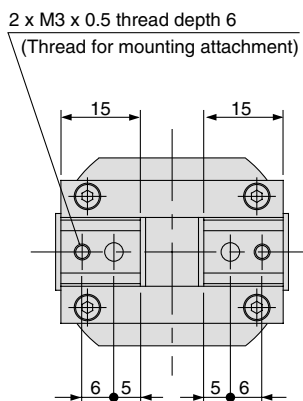
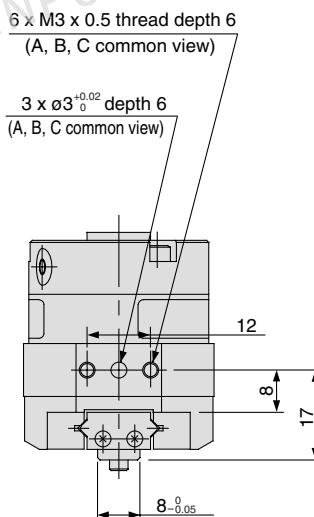
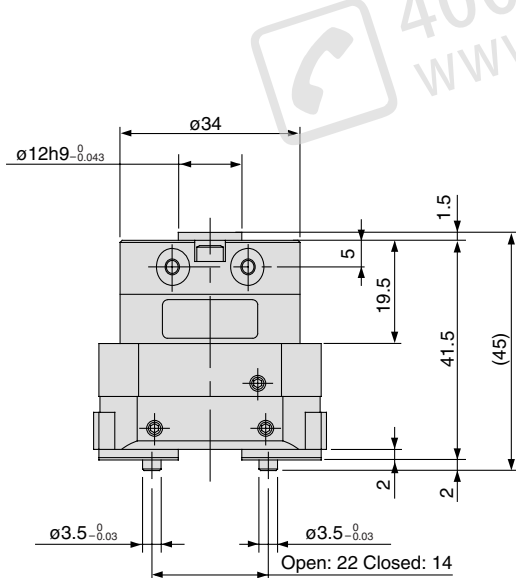
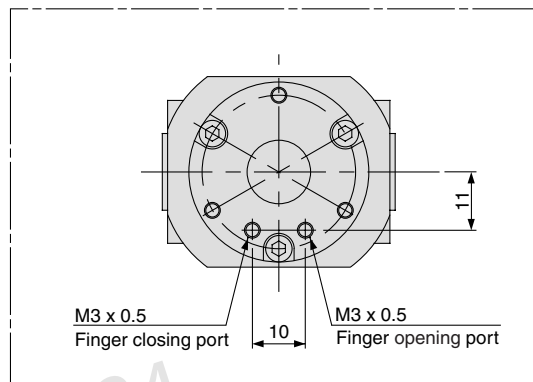

Rotary Actuated Air Gripper 2-Finger Type *Series MHR2/MDHR2*

With auto switch (Built-in magnet) : MDHR2-15R

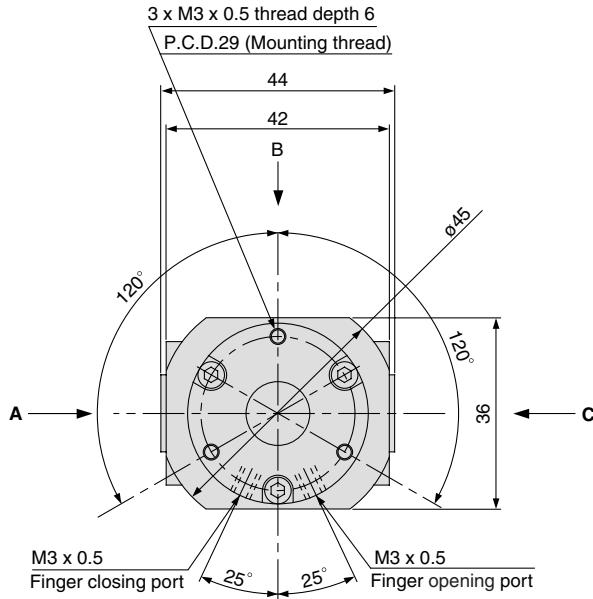

MDHR2-15E Port Location

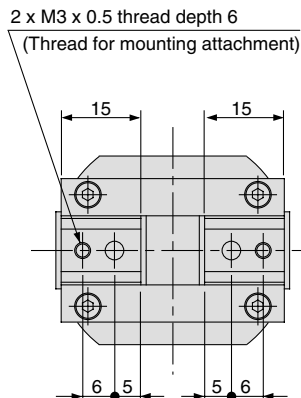
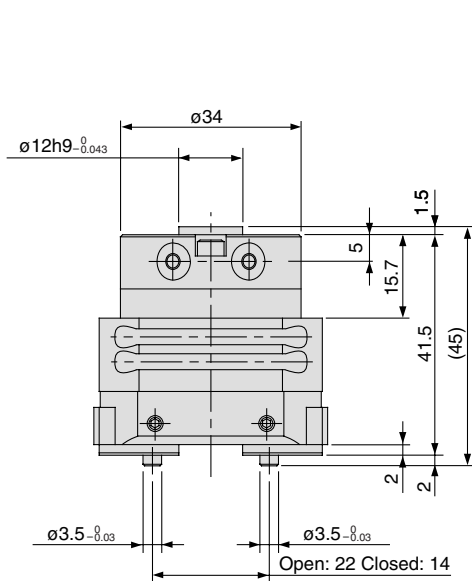
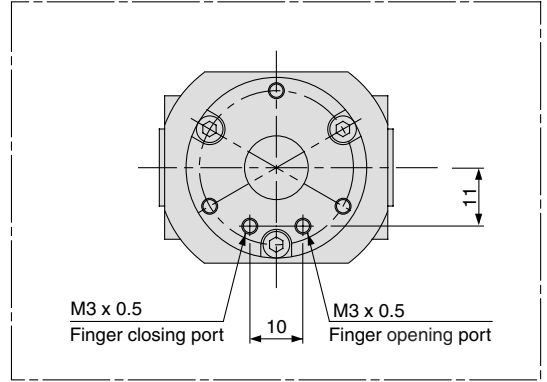

MHZ

MHF

MHL

MHR

MHK

MHS

MHC

MHT

MHY

MHW

-X□

MRHQ

MA

D-□

Series MHR2/MDHR2

Nominal Size 20

Without auto switch : MHR2-20R

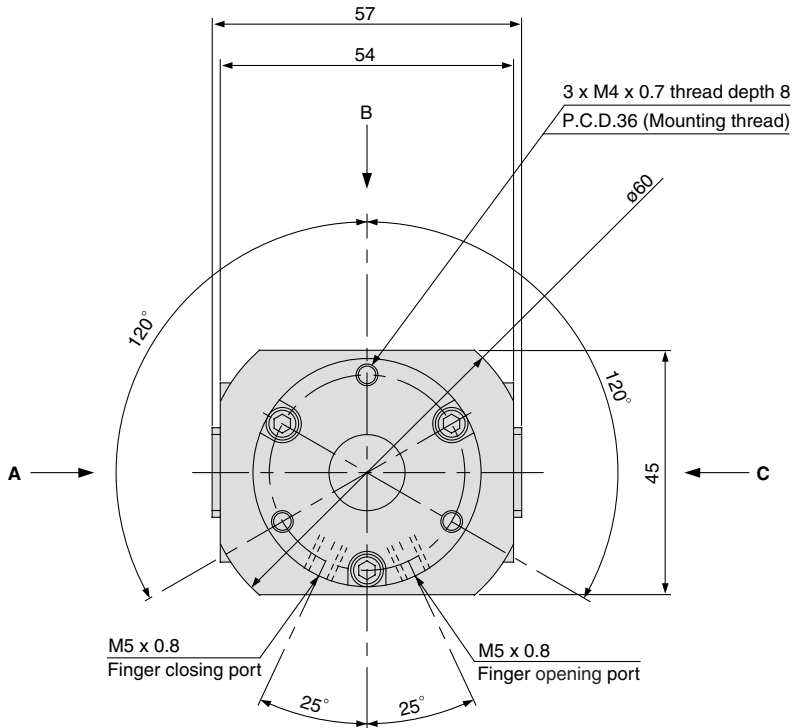

MHR2-20E Port Location

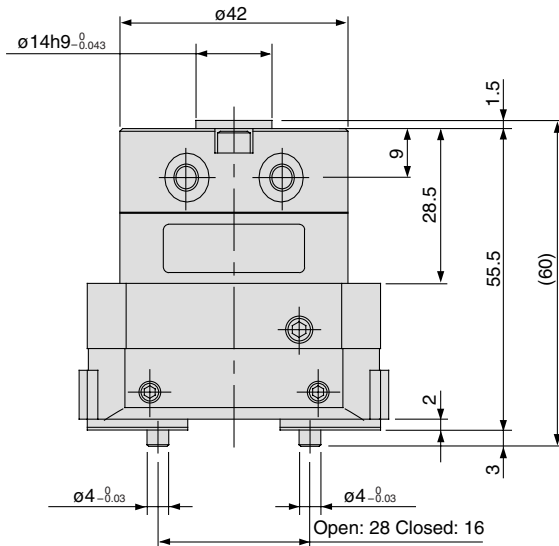
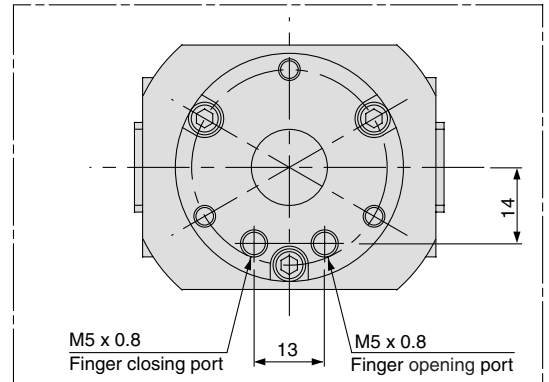

6 x M4 x 0.7 thread depth 8
(A, B, C common view)

3 x $\phi 4_{-0.02}^{+0.002}$ depth 8
(A, B, C common view)

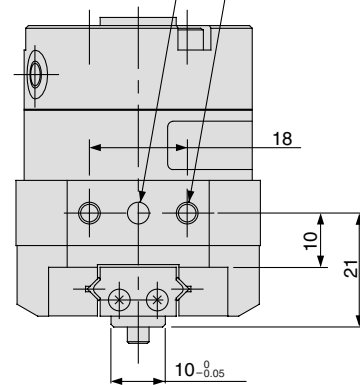

2 x M4 x 0.7 thread depth 8
(Thread for mounting attachment)

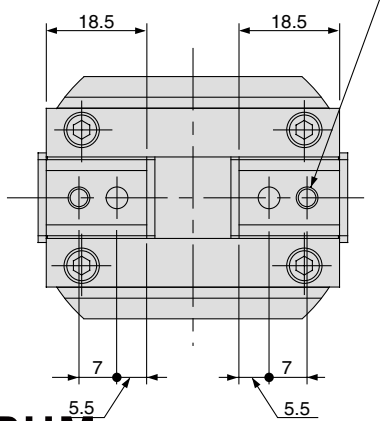

Rotary Actuated Air Gripper 2-Finger Type **Series MHR2/MDHR2**

With auto switch (Built-in magnet) : MDHR2-20R

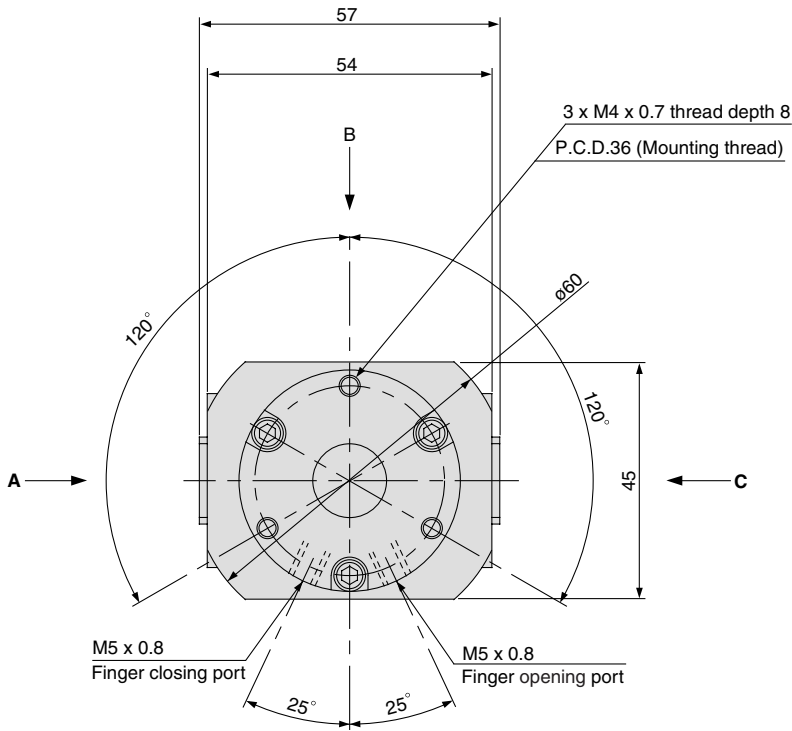

MDHR2-20E Port Location

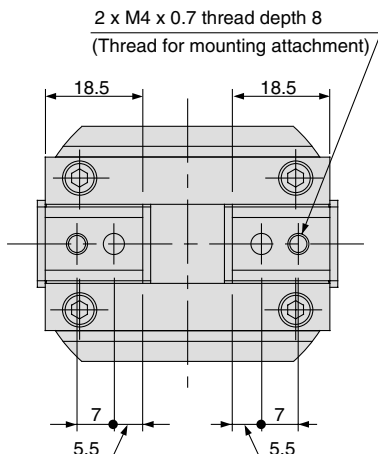
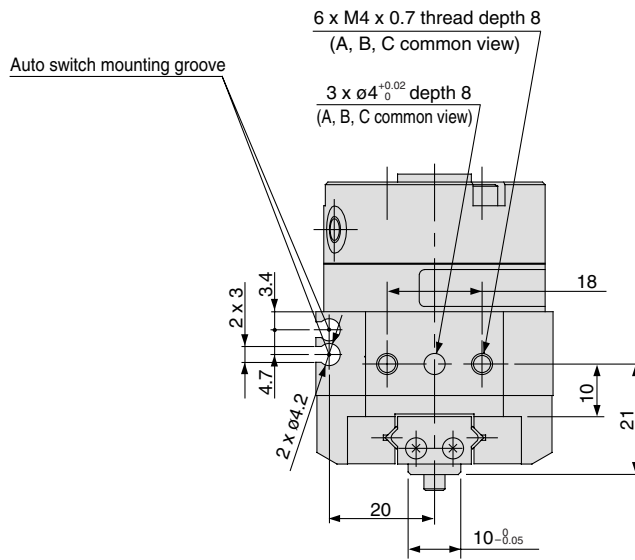
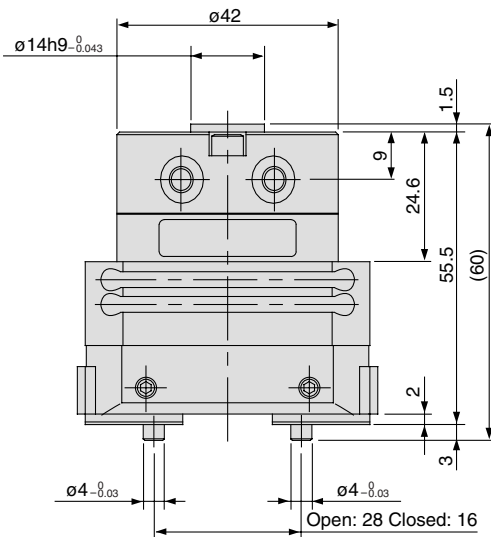
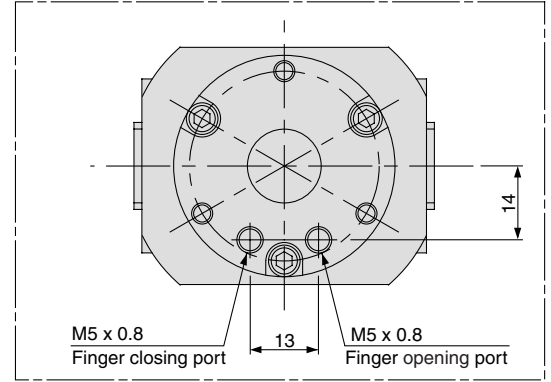

MHZ

MHF

MHL

MHR

MHK

MHS

MHC

MHT

MHY

MHW

-X□

MRHQ

MA

D-□

Rotary Actuated Air Gripper/3-Finger Type

Series *MHR3/MDHR3*

Size: 10, 15

How to Order

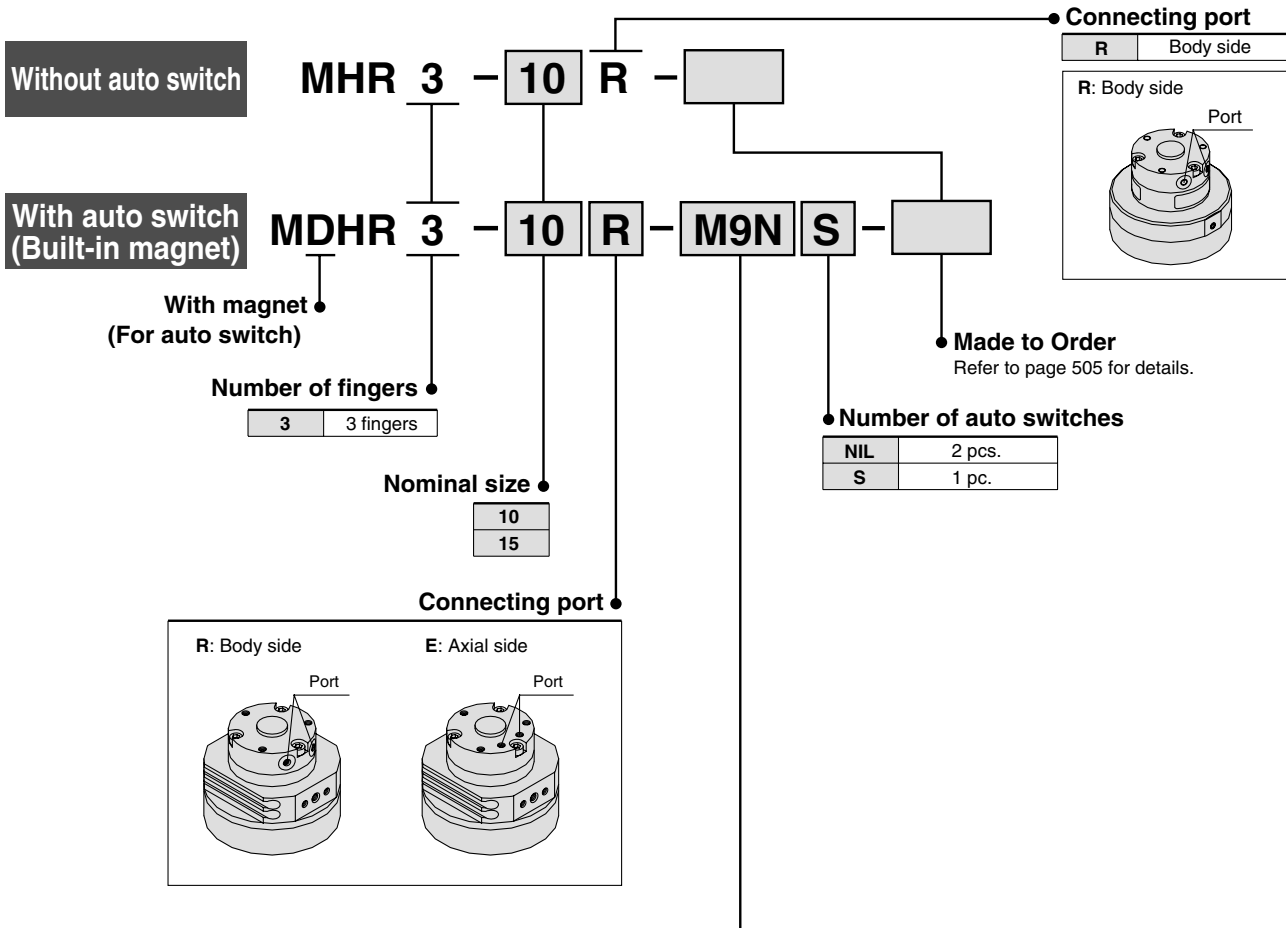

● **Applicable Auto Switch**/Refer to pages 761 to 809 for further information on auto switches.

Type	Special function	Electrical entry	Indicator light	Wiring (Output)	Load voltage		Auto switch model		Lead wire length (m)*				Pre-wired connector	Applicable load	
					DC	AC	Electrical entry direction		0.5 (Nil)	1 (M)	3 (L)	5 (Z)		IC circuit	Relay, PLC
							Perpendicular	In-line							
Solid state switch	—	Grommet	Yes	3-wire(NPN)	24V	5V, 12V	—	M9NV	M9N	●	●	●	○	—	—
				3-wire(PNP)				M9PV	M9P	●	●	●	○		
				2-wire				M9BV	M9B	●	●	●	○		

* Lead wire length symbols: 0.5 m..... Nil (Example) M9N
 1 m..... M (Example) M9NM
 3 m..... L (Example) M9NL
 5 m..... Z (Example) M9NZ

* Solid state auto switches marked with a "○" symbol are produced upon receipt of order.

Rotary Actuated Air Gripper 3-Finger Type *Series MHR3/MDHR3*



Model/Specifications

Nominal size		10	15
Action		Double acting	
Holding force (N) (Effective value)⁽¹⁾ at 0.5 MPa	External grip	7	13
	Internal grip	6.5	12
Opening/Closing stroke (Diameter)	Finger closing width (mm)	16	19
	Finger opening width (mm)	22	27
	Stroke (mm)	6	8
Mass (g)⁽²⁾		120 (125)	225 (230)
Connection port		M3 x 0.5	
Repeatability		± 0.01 mm	
Fluid		Air	
Operating pressure		0.2 to 0.6 MPa	0.15 to 0.6 MPa
Ambient and fluid temperature		0 to 60 °C	
Max. operating frequency		180 c.p.m	
Lubrication		Non-lube	

JIS Symbol

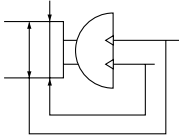

Note 1) Refer to page 506 "Effective Gripping Force" for details of gripping force at each gripping point.
 Valve of effective gripping force is measured at the middle of opening/closing stroke.
 Note 2) () Value shows MDHR mass, but it does not include auto switch mass.

When the finger opening/closing speed is set as the total stroke of 0.2 seconds or more, it may cause the product to stick or completely stop its movement.



Made to Order

Refer to page 683 to 713 for details.

Symbol	Specifications/Description
-X32	Countermeasure for condensation
-X63	Fluorine grease

MHZ

MHF

MHL

MHR

MHK

MHS

MHC

MHT

MHY

MHW

-X□

MRHQ

MA

D-□

Series MHR3/MDHR3

Gripping Point

External grip

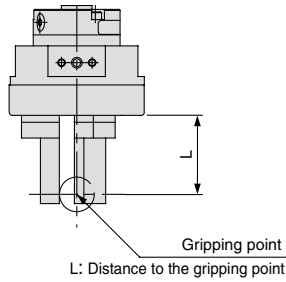

Internal grip

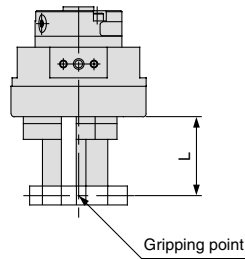

Limitation of Gripping: External Grip/Internal Grip

• Workpiece gripping point should be within the gripping point range: L shown below, by operating pressure.

• When the gripping point distance becomes large, the finger attachment applies an excessively large load to the finger sliding section, causing excessive play of the fingers and possibly leading to premature failure.

MHR3-10R/MDHR3-10□

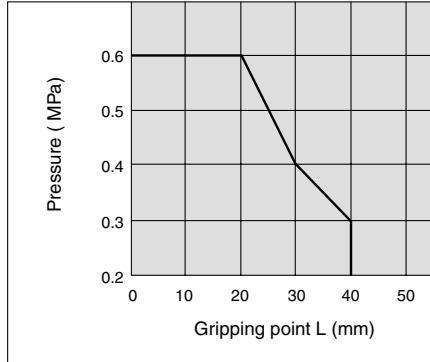

MHR3-15R/MDHR3-15□

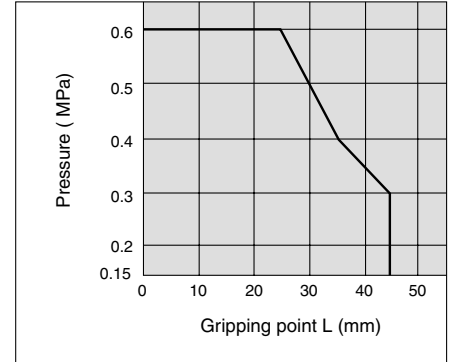

Effective Gripping Force

Guidelines for the selection of the gripper with respect to component mass

- Selection of the correct model depends upon the component mass, the coefficient of friction between the finger attachment and the component, and their respective configurations. A model should be selected with a gripping force of 7 to 14 times that of the component weight.
- If high acceleration, deceleration or impact forces are encountered during motion, a further margin of safety should be considered.

External grip

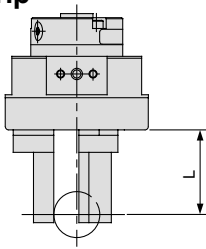

External Grip

MHR3-10R/MDHR3-10□

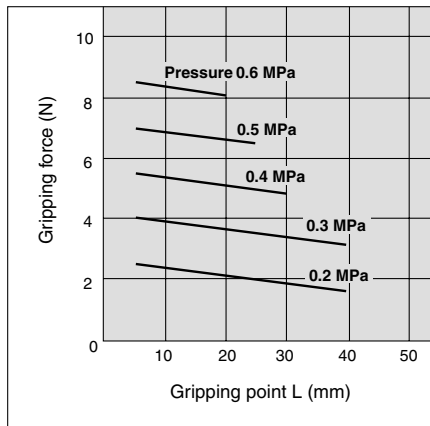

Internal Grip

MHR3-10R/MDHR3-10□

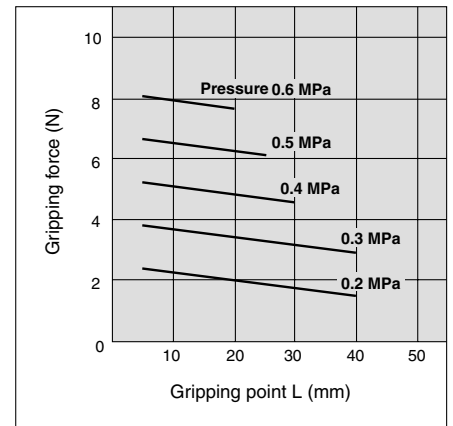

Internal grip

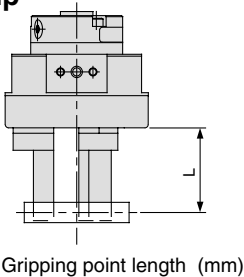

MHR3-15R/MDHR3-15□

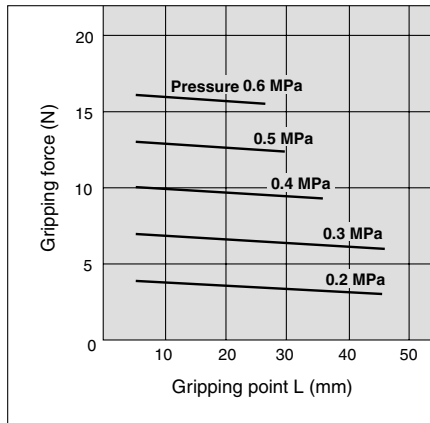

MHR3-15R/MDHR3-15□

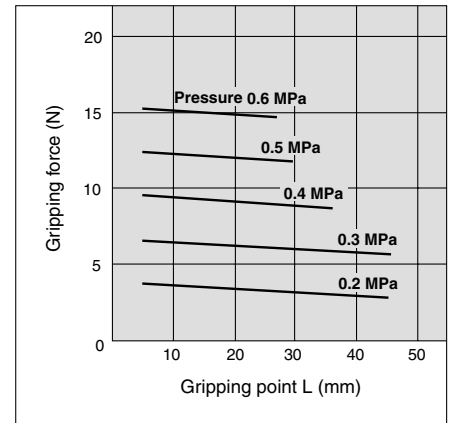

Indication of effective gripping force

The effective gripping force shown in the graphs to the right is expressed as F_1 , which is the thrust of one finger, when three fingers and attachments are in full contact with the workpiece as shown in the figure to the right.

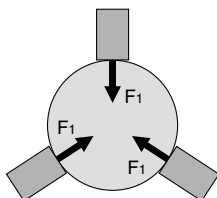

Construction

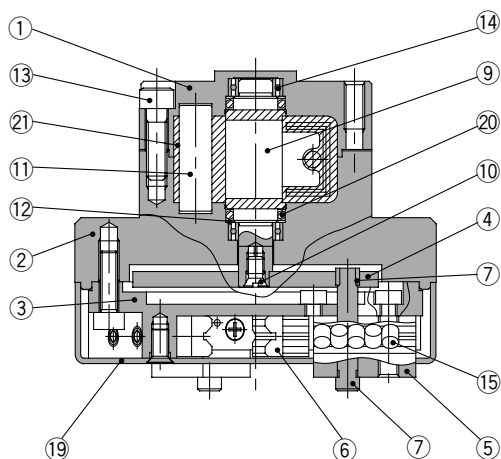

MDHR3

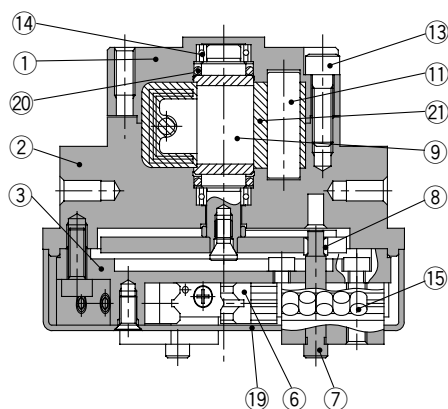
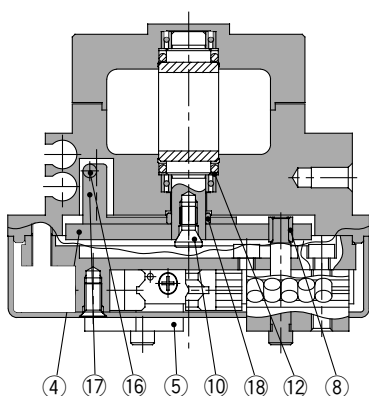

Component Parts

No.	Description	Material	Note
1	Body	Aluminum alloy	Hard anodized
2	Adaptor body	Aluminum alloy	Hard anodized
3	Guide holder	Stainless steel	
4	Cam	Cold rolled steel	Nitriding
5	Finger assembly	Stainless steel	Heat treated
6	Guide	Stainless steel	Heat treated
7	Pin	Carbon steel	Heat treated Electroless nickel plated
8	Pin roller	Stainless steel	Nitriding
9	Vane shaft	Stainless steel, NBR	
10	Joint bolt	Chrome molybdenum steel	Zinc chromated
11	Stopper	Resin	

No.	Description	Material	Note
12	Back-up ring	Stainless steel plate	
13	Hexagon socket head bolt	Stainless steel	
14	Bearing	High carbon chrome bearing steel	
15	Cylindrical roller	Stainless steel	
16	Magnet	—	
17	Magnet holder	Aluminum alloy	Hard anodized
18	Roller	Stainless steel	
19	Cover	Aluminum alloy	Hard anodized
20	O-ring	NBR	
21	Stopper seal	NBR	

Replacement Parts

Description	M□HR3-10□	M□HR3-15□	Main parts
Cover	P3313128	P3313228	⑰

MHZ

MHF

MHL

MHR

MHK

MHS

MHC

MHT

MHY

MHW

-X□

MRHQ

MA

D-□

Series MHR3/MDHR3

Nominal Size 10

Without auto switch: MHR3-10R

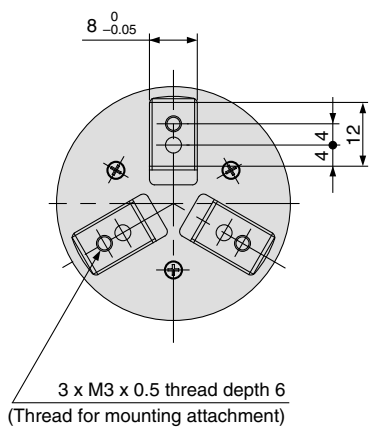
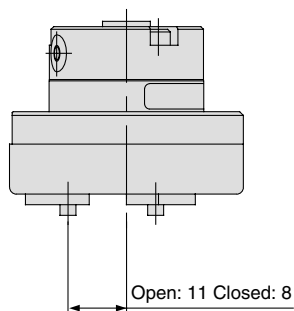
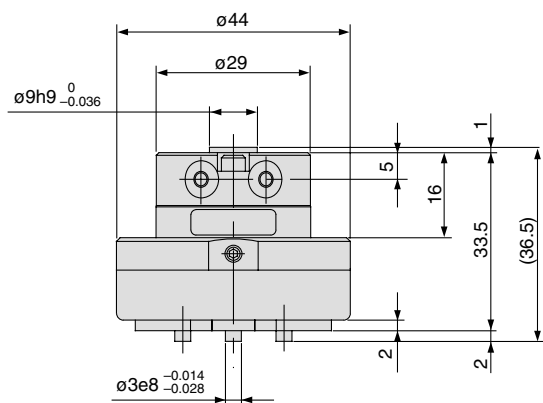
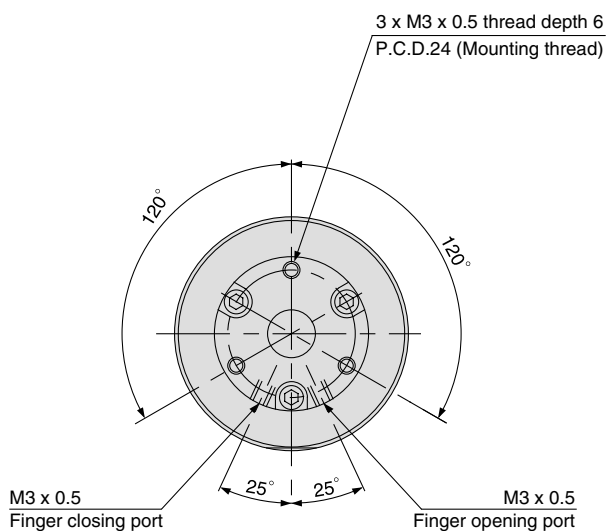

Rotary Actuated Air Gripper 3-Finger Type *Series MHR3/MDHR3*

With auto switch (Built-in magnet): MDHR3-10R

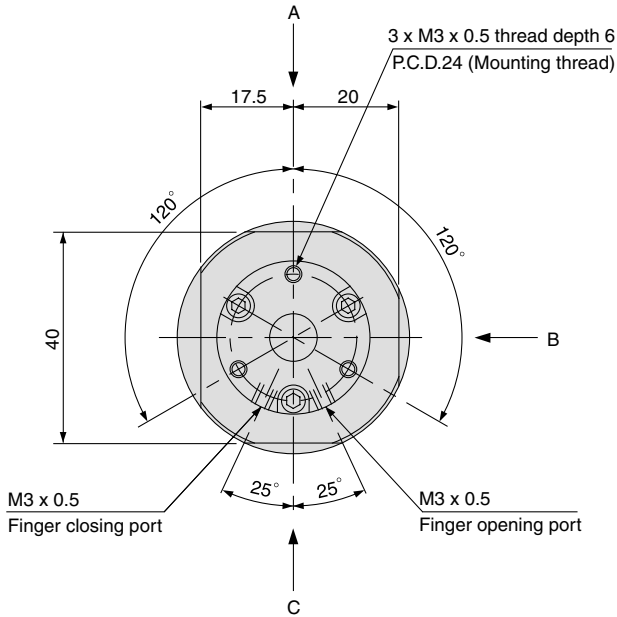

MDHR3-10E Port Location

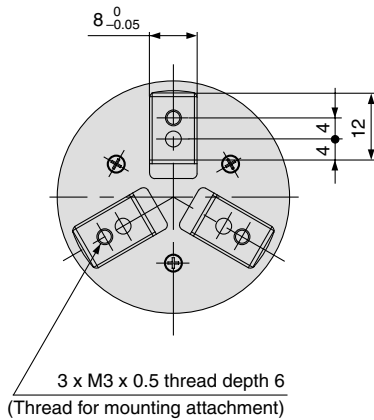
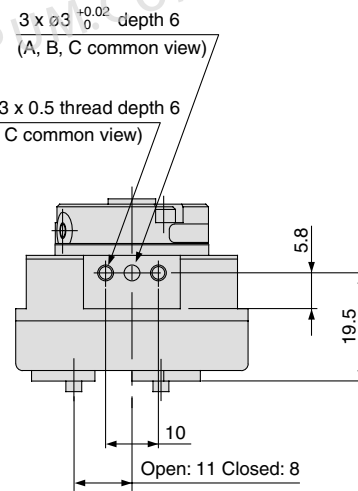
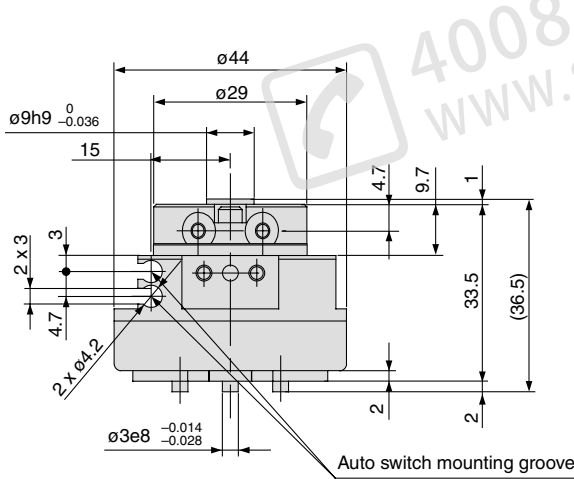
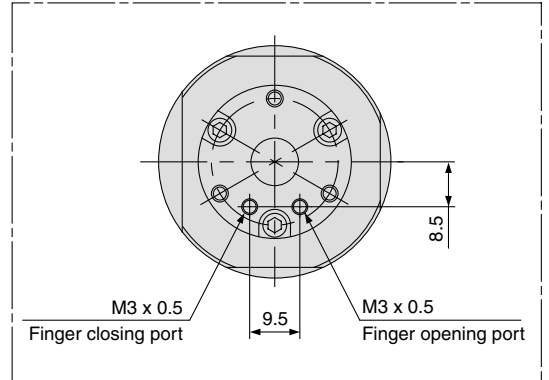

Dimensional Differences between MHR and MDHR

The following dimensions are different between series MHR and MDHR. And also, body shapes are different depending on auto switch mounting groove.

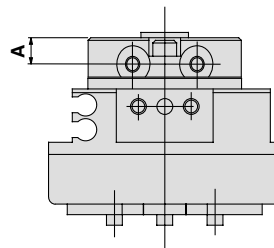

Model	A
MHR3-10R	5
MDHR3-10R	4.7

MHZ

MHF

MHL

MHR

MHK

MHS

MHC

MHT

MHY

MHW

-X□

MRHQ

MA

D-□

Series MHR3/MDHR3

Nominal Size 15

Without auto switch: MHR3-15R

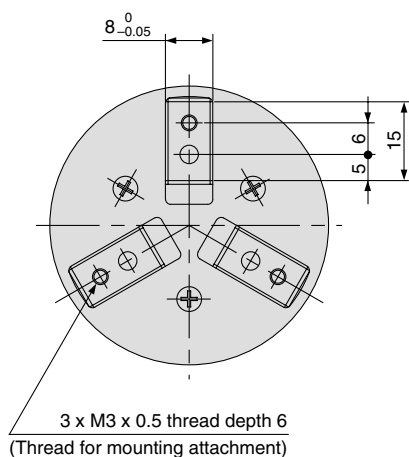
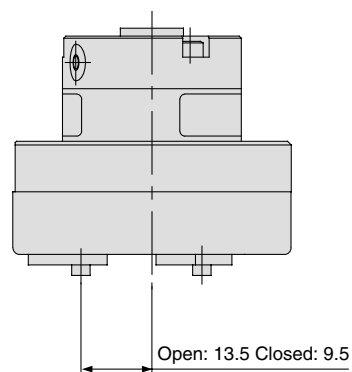
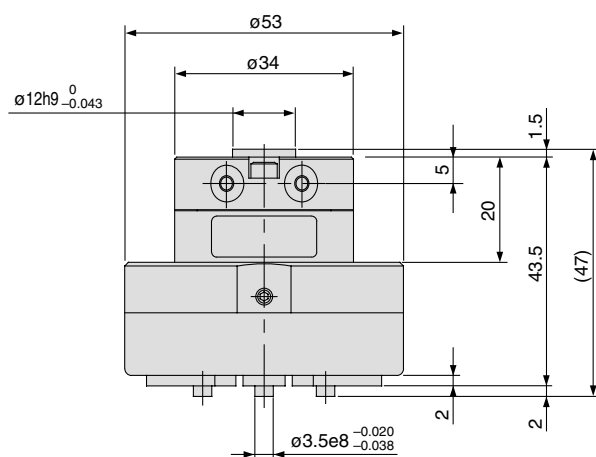
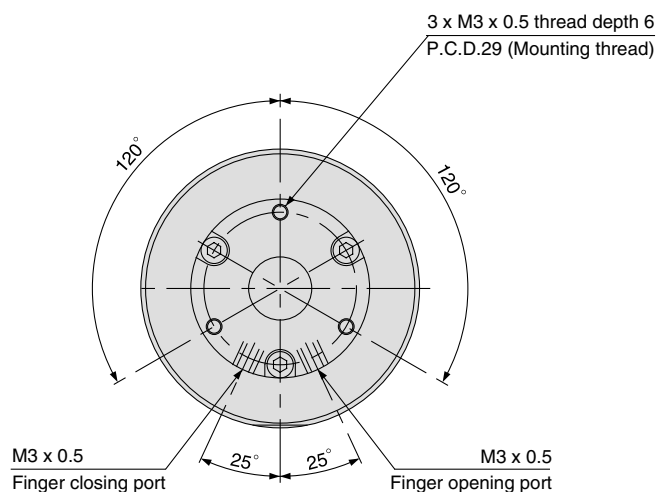

Rotary Actuated Air Gripper 3-Finger Type **Series MHR3/MDHR3**

With auto switch (Built-in magnet): MDHR3-15R

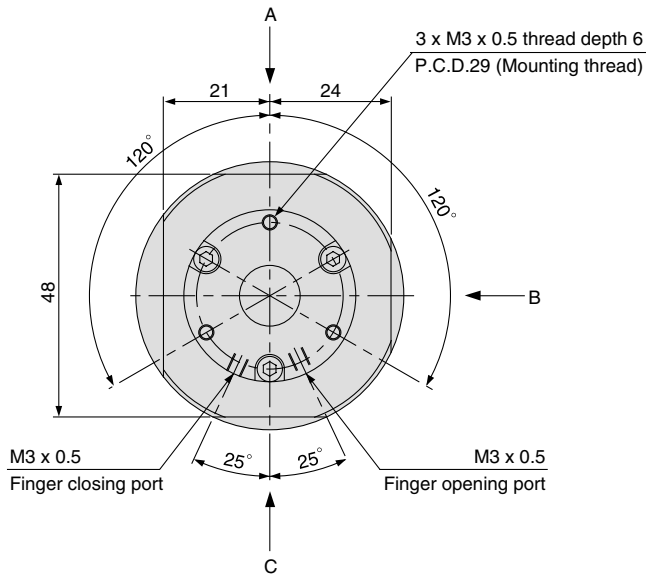

MDHR3-15E Port Location

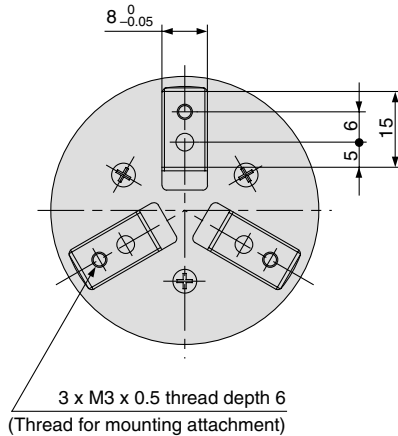
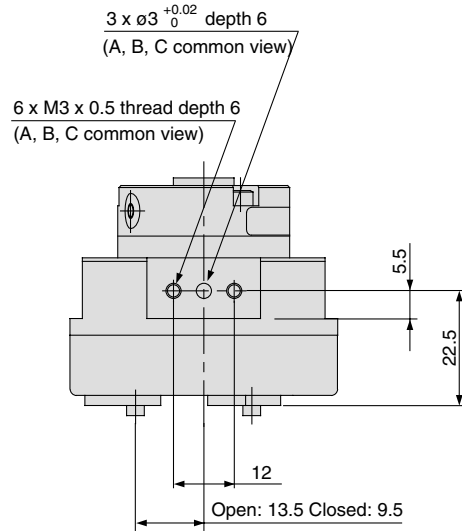
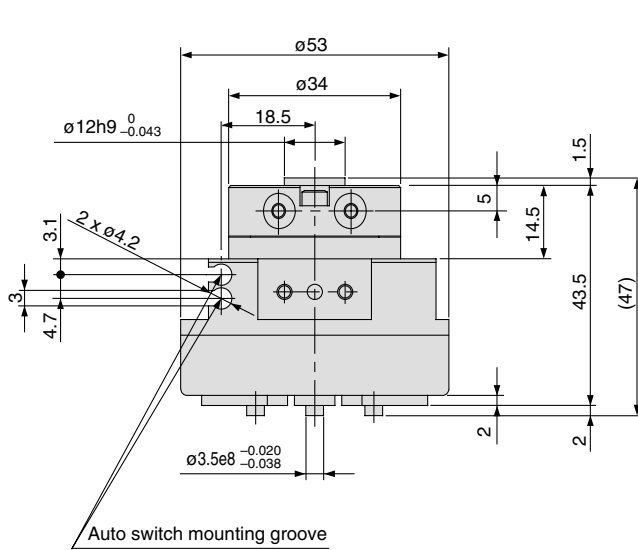
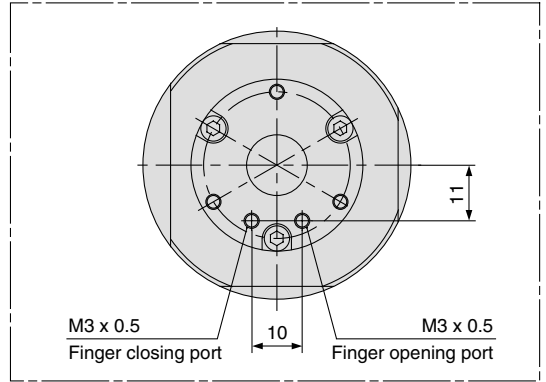

MHZ

MHF

MHL

MHR

MHK

MHS

MHC

MHT

MHY

MHW

-X□

MRHQ

MA

D-□

Series MDHR2/MDHR3 Auto Switch Installation Examples and Mounting Positions

Various auto switch applications are possible through different combinations of auto switch quantities and detecting positions.

1) Detection when Gripping Exterior of Workpiece/Auto Switch Mounted from Direction A

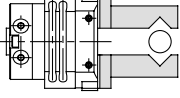
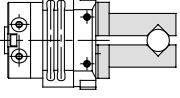
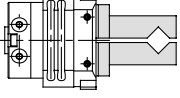
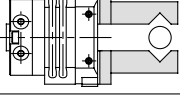
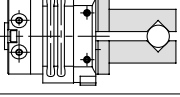
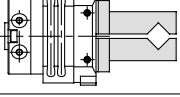
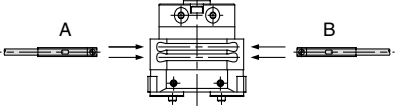
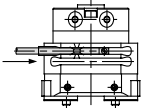
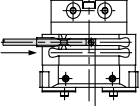
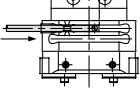
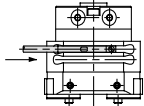
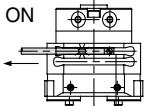
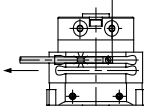
Detection example		1. Confirmation of fingers in reset position	2. Confirmation of workpiece held	3. Confirmation of workpiece released	
Position to be detected		Position of fingers fully opened 	Position when gripping a workpiece 	Position of fingers fully closed 	
Operation of auto switch		Auto switch turned ON when fingers return. (Light ON)	Auto switch turned ON when gripping a workpiece. (Light ON)	When a workpiece is held (Normal operation): Auto switch to turn OFF (Light not illuminating) When a workpiece is not held (Abnormal operation): Auto switch to turn ON (Light illuminating)	
Detection combinations	One auto switch	●			
			●		
	Two auto switches	●—————●	●	●	
●—————●		●	●		
How to determine auto switch installation position		Step 1) Fully open the fingers. 	Step 1) Position fingers for gripping a workpiece. 	Step 1) Fully close the fingers. 	
At no pressure or low pressure, connect the auto switch to a power supply, and follow the directions.		In the case of mounting auto switch from A direction Step 2) Insert the auto switch into the auto switch installation groove from direction A. 			
		Step 3) Slide the auto switch in the direction of the arrow until the light illuminates and fasten it at a position 0.3 to 0.5 mm in the direction of the arrow beyond the position where the indicator light illuminates.	Step 3) Slide the auto switch in the direction of the arrow until the indicator light illuminates. 		
		Position where light turns ON  0.3 to 0.5mm Position to be secured 	Step 4) Slide the auto switch in the direction of the arrow until the indicator light goes out. 		
		Step 5) Move the auto switch in the opposite direction, and fasten it at a position 0.3 to 0.5 mm in the direction of the arrow beyond the position where the indicator light illuminates.	Step 5) Move the auto switch in the opposite direction, and fasten it at a position 0.3 to 0.5 mm in the direction of the arrow beyond the position where the indicator light illuminates. Position where light turns ON  0.3 to 0.5 mm Position to be secured 		
			Note 1) It is recommended that gripping of a workpiece be performed close to the center of the finger stroke. Note 2) When holding a workpiece close at the end of open/close stroke of fingers, detecting performance of the combinations listed in the above table may be limited, depending on the hysteresis of an auto switch, etc.		

Note 1) It is recommended that gripping of a workpiece be performed close to the center of the finger stroke.
Note 2) When holding a workpiece close at the end of open/close stroke of fingers, detecting performance of the combinations listed in the above table may be limited, depending on the hysteresis of an auto switch, etc.

2) Detection when Gripping Exterior of Workpiece/Auto Switch Mounted from Direction B

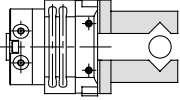
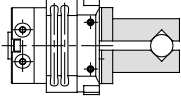
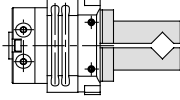
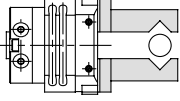
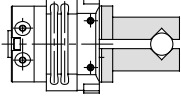
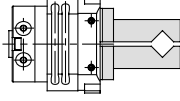
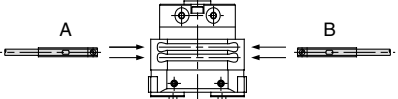
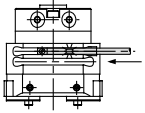
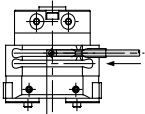
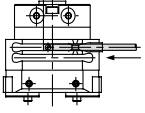
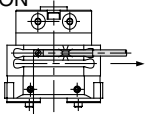
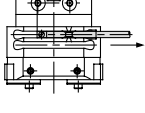
Detection example		1. Confirmation of fingers in reset position	2. Confirmation of workpiece held	3. Confirmation of workpiece released
Position to be detected		Position of fingers fully opened 	Position when gripping a workpiece 	Position of fingers fully closed 
Operation of auto switch		Auto switch turned ON when fingers return. (Light ON)	Auto switch turned ON when gripping a workpiece. (Light ON)	When a workpiece is held (Normal operation): Auto switch to turn OFF (Light not illuminating) When a workpiece is not held (Abnormal operation): Auto switch to turn ON (Light illuminating)
Detection combinations	One auto switch	●	●	●
	Two auto switches	●	●	●
	Two auto switches	●	●	●
	Two auto switches	●	●	●
How to determine auto switch installation position		Step 1) Fully open the fingers. 	Step 1) Position fingers for gripping a workpiece. 	Step 1) Fully close the fingers. 
At no pressure or low pressure, connect the auto switch to a power supply, and follow the directions.		<p>In the case of mounting auto switch from B direction</p> <p>Step 2) Insert the auto switch into the auto switch installation groove from direction B.</p> 		
Step 3) Slide the auto switch in the direction of the arrow until the indicator light illuminates.		<p>Step 3) Slide the auto switch in the direction of the arrow until the indicator light illuminates. Move the switch an additional 0.3 to 0.5 mm in the direction of the arrow and fasten it.</p> 		
Step 4) Slide the auto switch in the direction of the arrow until the indicator light goes out		<p>Position where light turns ON</p>  <p style="text-align: center;">0.3 to 0.5 mm</p> <p>Position to be secured</p> 		
Step 5) Move the auto switch in the opposite direction and fasten it at a position 0.3 to 0.5 mm beyond the position where the indicator light illuminates.		<p>Position where light turns ON</p>  <p style="text-align: center;">0.3 to 0.5 mm</p> <p>Position to be secured</p> 		

 Note 1) It is recommended that gripping of a workpiece be performed close to the center of the finger stroke.
 Note 2) When holding a workpiece close at the end of open/close stroke of fingers, detecting performance of the combinations listed in the above table may be limited, depending on the hysteresis of an auto switch etc.

MHZ

MHF

MHL

MHR

MHK

MHS

MHC

MHT

MHY

MHW

-X□

MRHQ

MA

D-□

Series MDHR2/MDHR3

Auto Switch Installation Examples and Mounting Positions

Various auto switch applications are possible through different combinations of auto switch quantities and detecting positions.

3) Detection when Gripping Interior of Workpiece/Auto Switch Mounted from Direction A

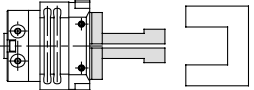
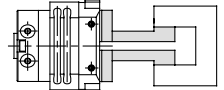
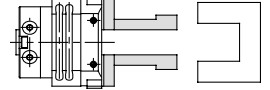
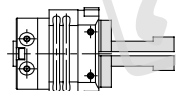
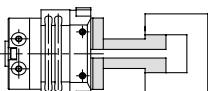
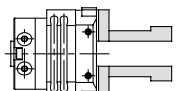
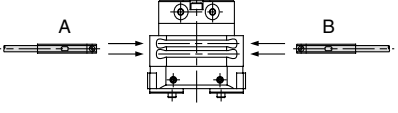
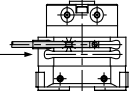
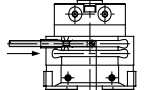
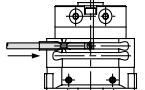
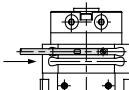
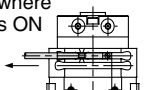
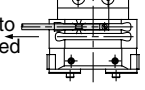
Detection example		1. Confirmation of fingers in reset position	2. Confirmation of workpiece held	3. Confirmation of workpiece released	
Position to be detected		Position of fingers fully closed 	Position when gripping a workpiece 	Position of fingers fully opened 	
Operation of auto switch		Auto switch turned ON when fingers return. (Light ON)	Auto switch turned ON when gripping a workpiece. (Light ON)	When a workpiece is held (Normal operation): Auto switch to turn OFF (Light not illuminating) When a workpiece is not held (Abnormal operation): Auto switch to turn ON (Light illuminating)	
Detection combinations	One auto switch	●	●	●	
	Two auto switches	● ————— ●	● ————— ●	● ————— ●	
		● ————— ●	● ————— ●	● ————— ●	
How to determine auto switch installation position		Step 1) Fully close the fingers. 	Step 1) Position fingers for gripping a workpiece. 	Step 1) Fully open the fingers. 	
At no pressure or low pressure, connect the auto switch to a power supply, and follow the directions.		In the case of mounting auto switch from A direction Step 2) Insert the auto switch into the auto switch installation groove from direction A. 			
		Step 3) Slide the auto switch in the direction of the arrow until the indicator light illuminates. 	Step 3) Slide the auto switch in the direction of the arrow until the indicator light illuminates. Move the switch an additional 0.3 to 0.5 mm in the direction of the arrow and fasten it. Position where light turns ON  0.3 to 0.5 mm Position to be secured 		
		Step 4) Slide the auto switch in the direction of the arrow until the indicator light goes out. 	Step 5) Move the auto switch in the opposite direction and fasten it at a position 0.3 to 0.5 mm beyond the position where the indicator light illuminates. Position where light turns ON  0.3 to 0.5 mm Position to be secured 		

Note 1) It is recommended that gripping of a workpiece be performed close to the center of the finger stroke.
 Note 2) When holding a workpiece close at the end of open/close stroke of fingers, detecting performance of the combinations listed in the above table may be limited, depending on the hysteresis of an auto switch, etc.

4) Detection when Gripping Interior of Workpiece/Auto Switch Mounted from Direction B

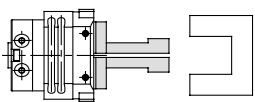
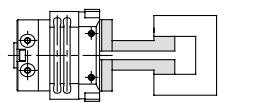
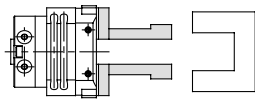
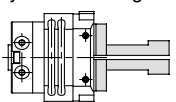
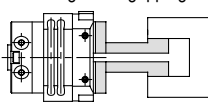
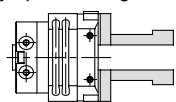
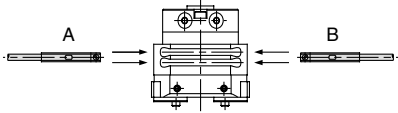
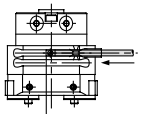
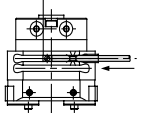
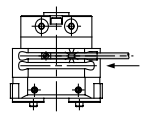
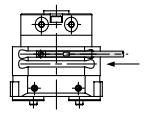
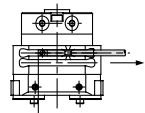
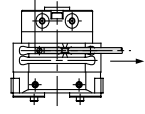
Detection example		1. Confirmation of fingers in reset position	2. Confirmation of workpiece held	3. Confirmation of workpiece released
Position to be detected		Position of fingers fully closed 	Position when gripping a workpiece 	Position of fingers fully opened 
Operation of auto switch		Auto switch turned ON when fingers return. (Light ON)	Auto switch turned ON when gripping a workpiece. (Light ON)	When a workpiece is held (Normal operation): Auto switch to turn OFF (Light not illuminating) When a workpiece is not held (Abnormal operation): Auto switch to turn ON (Light)
Detection combinations	One auto switch	●	●	●
	Two auto switches	● ————— ●	● ————— ●	● ————— ●
		● ————— ●	● ————— ●	● ————— ●
How to determine auto switch installation position		Step 1) Fully close the fingers. 	Step 1) Position fingers for gripping a workpiece. 	Step 1) Fully open the fingers. 
At no pressure or low pressure, connect the auto switch to a power supply, and follow the directions.		<p>In the case of mounting auto switch from B direction</p> <p>Step 2) Insert the auto switch into the auto switch installation groove from direction B.</p> <div style="text-align: center;">  </div>		
<p>Step 3) Slide the auto switch in the direction of the arrow until the light illuminates and fasten it at a position 0.3 to 0.5 mm in the direction of the arrow beyond the position where the indicator light illuminates.</p> <p style="text-align: center;">Position where light turns ON</p> <div style="text-align: center;">  </div> <p style="text-align: center;">Position to be secured</p> <div style="text-align: center;">  </div>		<p>Step 3) Slide the auto switch in the direction of the arrow until the indicator light illuminates.</p> <div style="text-align: center;">  </div> <p>Step 4) Slide the auto switch in the direction of the arrow until the indicator light goes out.</p> <div style="text-align: center;">  </div> <p>Step 5) Move the auto switch in the opposite direction, and fasten it at a position 0.3 to 0.5 mm in the direction of the arrow beyond the position where the indicator light illuminates.</p> <p style="text-align: center;">Position where light turns ON</p> <div style="text-align: center;">  </div> <p style="text-align: center;">Position to be secured</p> <div style="text-align: center;">  </div>		

- MHZ
- MHF
- MHL
- MHR
- MHK
- MHS
- MHC
- MHT
- MHY
- MHW
- X□
- MRHQ
- MA
- D-□

 Note 1) It is recommended that gripping of a workpiece be performed close to the center of the finger stroke.
 Note 2) When holding a workpiece close at the end of open/close stroke of fingers, detecting performance of the combinations listed in the above table may be limited, depending on the hysteresis of an auto switch, etc.

Series MHR2/MDHR2

Auto Switch Mounting

To set the auto switch, insert the auto switch into the installation groove of the gripper from the direction indicated in the following drawing. After setting the position, tighten the attached auto switch mounting set screw with a flat head watchmaker's screwdriver.

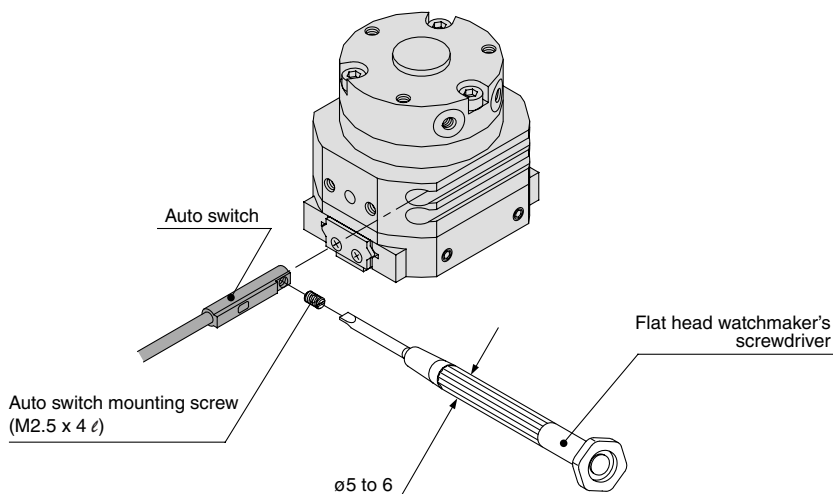

Note) Use a watchmaker's screwdriver with a grip diameter of 5 to 6 mm to tighten the auto switch mounting screw. The tightening torque should be about 0.05 to 0.15 N-m.

Auto Switch Hysteresis

Please refer to the table as a guide when setting auto switch positions.

Model	Hysteresis (Max. value) (mm)
MDHR2-10	0.3
MDHR2-15	0.2
MDHR2-20	0.6
MDHR2-30	0.3

MDHR2

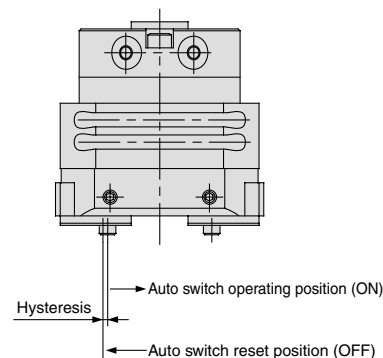

Protrusion of Auto Switch from Edge of Body

The maximum protrusion of an auto switch (when fingers are fully open) from the edge of the body is shown in the table below. Use the table as a guideline for mounting.

MDHR2-10, 15

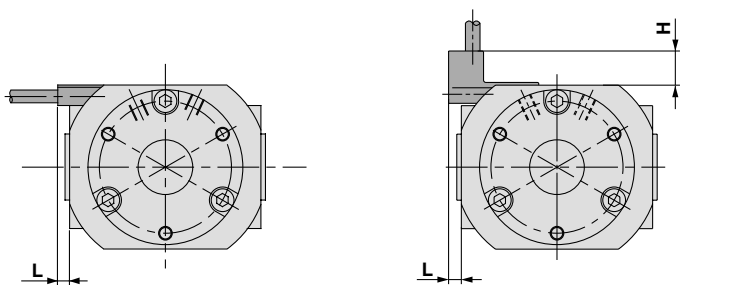

Auto switches of D-M9N, D-M9P and D-M9B are used.

Auto switches of D-M9NV, D-M9PV and D-M9BV are used.

Max. Protrusion of Auto Switch from Edge of Body: L, H (mm)

Auto switch model		D-M9□	D-M9□V
Air gripper model	L	2.6	0.6
	H	—	7
MDHR2-15	L	—	—
	H	—	7

MDHR2-20, 30

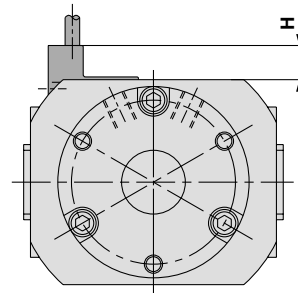

Auto switches of D-M9NV, D-M9PV and D-M9BV are used.

Max. Protrusion of Auto Switch from Edge of Body: H (mm)

Auto switch model	D-M9□V
MDHR2-20	7
MDHR2-30	7

The auto switch will not protrude in the case of D-M9□.

Auto Switch Mounting

To set the auto switch, insert the auto switch into the installation groove of the gripper from the direction indicated in the following drawing. After setting the position, tighten the attached auto switch mounting set screw with a flat head watchmaker's screwdriver.

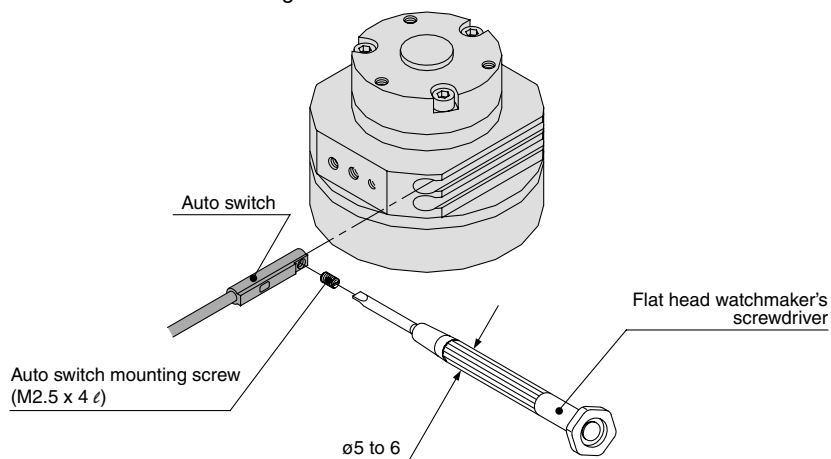

Note) Use a watchmaker's screwdriver with a grip diameter of 5 to 6 mm to tighten the auto switch mounting screw. The tightening torque should be about 0.05 to 0.15 N·m.

Auto Switch Hysteresis

Please refer to the table as a guide when setting auto switch positions.

Model	Hysteresis (Max.value) (mm)
MDHR3-10	0.2
MDHR3-15	0.5

MDHR3

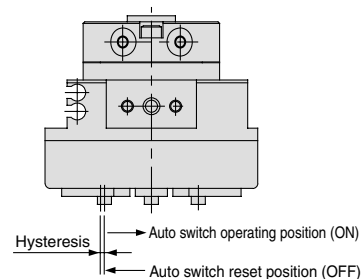

Protrusion of Auto Switch from Edge of Body

The maximum protrusion of an auto switch (when fingers are fully open) from the edge of the body is shown in the table below. Use the table as a guideline for mounting.

MDHR3-10

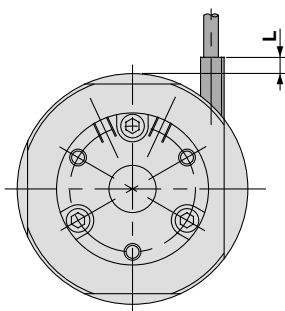

When auto switch D-M9□ is used

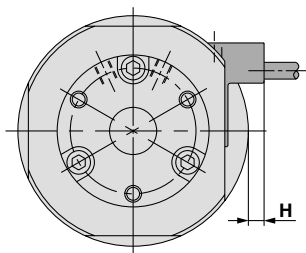

When auto switch D-M9□V is used

Max. Protrusion of Auto Switch from Edge of Body: L, H (mm)

Auto switch model	D-M9□	D-M9□V
L	—	—
H	—	2.5

MDHR3-15

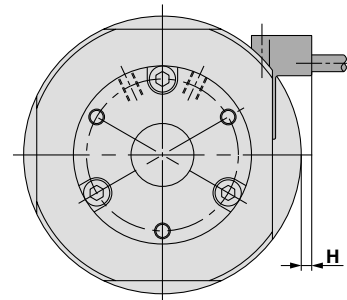

When auto switch D-M9□V is used

Max. Protrusion of Auto Switch from Edge of Body: H (mm)

Auto switch model	D-M9□V
H	1.5

The auto switch will not protrude in the case of D-M9□.

MHZ

MHF

MHL

MHR

MHK

MHS

MHC

MHT

MHY

MHW

-X□

MRHQ

MA

D-□



Series MHR2, MDHR2/MHR3, MDHR3 Specific Product Precautions

Be sure to read before handling.

Mounting Air Grippers/MHR2/MHR3

Mounting direction of each model is different. Refer to the table at right.

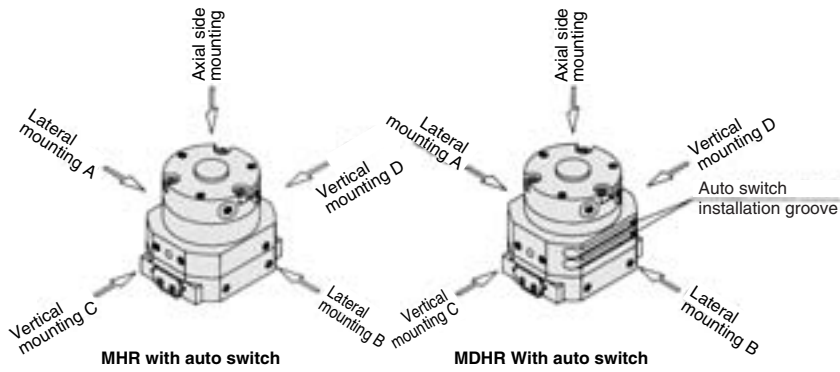

Model	Axial side mounting	Lateral mounting		Vertical mounting	
		A	B	C	D
MHR2-□	●	●	—	●	●
MHR3-□	●	—	—	—	—
MDHR2-□	●	●	—	●	●
MDHR3-□	●	●	●	—	●

Axial side mounting

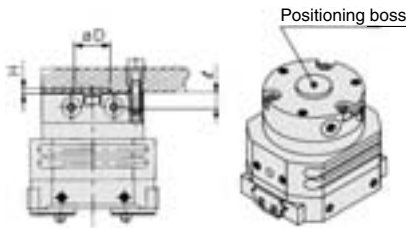

Model	Applicable bolt	Max. tightening torque N·m	Max. screw-in depth \varnothing mm	Positioning boss		
				Dmm	Hmm	
MHR 2	-10	M3 x 0.5	0.88	6	9h9 ₀ ^{-0.036}	1
	-15				12h9 ₀ ^{-0.043}	1.5
	-20	M4 x 0.7	2.1	8	14h9 ₀ ^{-0.043}	1.5
MDHR	-30	M5 x 0.8	4.3	10	16h9 ₀ ^{-0.043}	2
	3	M3 x 0.5	0.88	6	9h9 ₀ ^{-0.036}	1
12h9 ₀ ^{-0.043}					1.5	

Lateral mounting

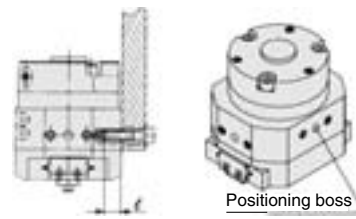

Model	Applicable bolt	Max. tightening torque N·m	Max. screw-in depth \varnothing mm	Positioning boss		
				Bore Depth dmm	Bore Depth hmm	
MHR 2	-10	M3 x 0.5	0.88	6	3 ^{+0.02} ₀	6
	-15				4 ^{+0.02} ₀	8
	-20	M4 x 0.7	2.1	8	5 ^{+0.02} ₀	10
MDHR	-30	M5 x 0.8	4.3	10	5 ^{+0.02} ₀	10
	3	M3 x 0.5	0.88	6	3 ^{+0.02} ₀	6
-15					3 ^{+0.02} ₀	6

Vertical mounting

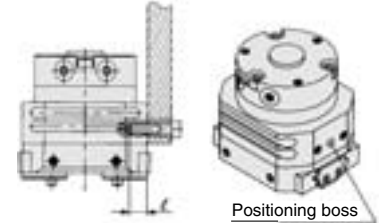

Model	Applicable bolt	Max. tightening torque N·m	Max. screw-in depth \varnothing mm	Positioning boss		
				Bore Depth dmm	Bore Depth hmm	
MHR 2	-10	M3 x 0.5	0.88	6	3 ^{+0.02} ₀	6
	-15				4 ^{+0.02} ₀	8
	-20	M4 x 0.7	2.1	8	5 ^{+0.02} ₀	10
MDHR	-30	M5 x 0.8	4.3	10	5 ^{+0.02} ₀	10
	3	M3 x 0.5	0.88	6	3 ^{+0.02} ₀	6
-15					3 ^{+0.02} ₀	6

How to Locate Finger and Attachment

- Positioning in the finger's open/close direction**
 Position the finger and the attachment by inserting the finger's pin into the attachment's pin insertion hole. Provide the following pin insertion hole dimensions: shaft-basis fitting dimension C for the open/close direction; slotted hole with relief B for the cross direction.
- Positioning in the finger's cross direction**
 Position the finger and the attachment by placing the finger's width into the attachment's finger insertion groove A.

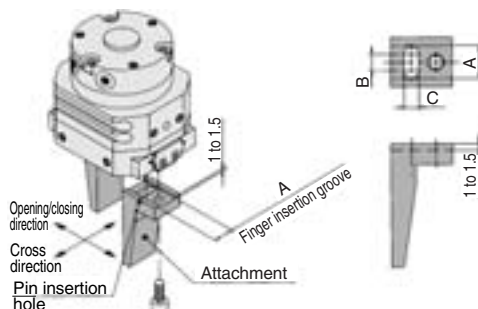

How to Mount the Attachment to the Finger

- To mount the attachment to the finger, make sure to use a wrench to support the attachment so as not to apply undue strain on the finger.
- Refer to the table below for the proper tightening torque on the bolt used for securing the attachment to the finger.

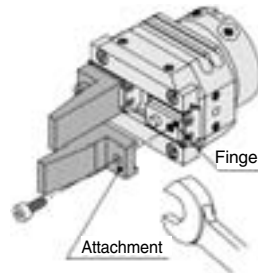

Model	Applicable bolt	Max. tightening torque N·m	
			MHR 2
MDHR	-15	M4 x 0.7	1.4
	-20	M5 x 0.8	2.8
	3	-10	M3 x 0.5
	-15	M3 x 0.5	0.59

Finger opening/closing speed: MHR2/MHR3

When the finger opening/closing speed is set as the total stroke of 0.2 seconds or more, it may cause the product to stick or completely stop its movement.



Series MHR2, MDHR2/MHR3, MDHR3 Specific Product Precautions

Be sure to read before handling.

Mounting Air Grippers/MHR2/MHR3

Mounting direction of each model is different. Refer to the table at right.

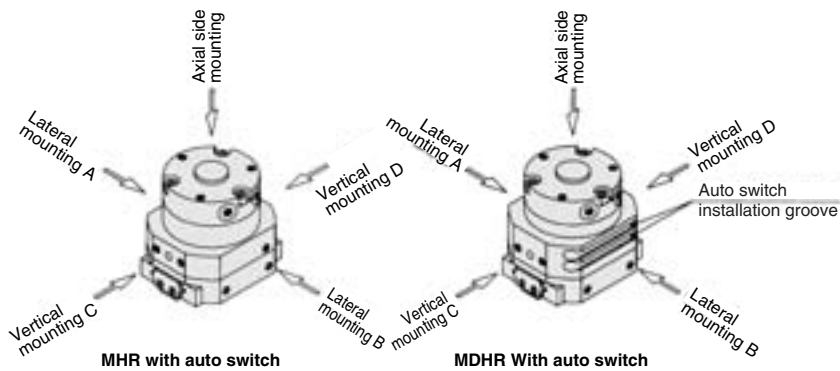

Model	Axial side mounting	Lateral mounting		Vertical mounting	
		A	B	C	D
MHR2-□	●	●	—	●	●
MHR3-□	●	—	—	—	—
MDHR2-□	●	●	—	●	●
MDHR3-□	●	●	●	—	●

Axial side mounting

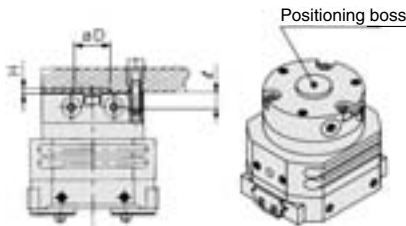

Model	Applicable bolt	Max. tightening torque N·m	Max. screw-in depth \varnothing mm	Positioning boss		
				Dmm	Hmm	
MHR 2	-10	M3 x 0.5	0.88	6	9h9 ₀ ⁰ _{-0.036}	1
	-15				12h9 ₀ ⁰ _{-0.043}	
	-20	M4 x 0.7	2.1	8	14h9 ₀ ⁰ _{-0.043}	1.5
MDHR	-30	M5 x 0.8	4.3	10	16h9 ₀ ⁰ _{-0.043}	2
	3	M3 x 0.5	0.88	6	9h9 ₀ ⁰ _{-0.036}	1
-15					12h9 ₀ ⁰ _{-0.043}	

Lateral mounting

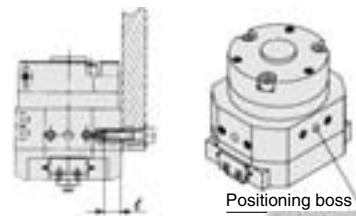

Model	Applicable bolt	Max. tightening torque N·m	Max. screw-in depth \varnothing mm	Positioning boss		
				Bore Depth dmm	Bore Depth hmm	
MHR 2	-10	M3 x 0.5	0.88	6	3 ^{+0.02} ₀	6
	-15				4 ^{+0.02} ₀	
	-20	M4 x 0.7	2.1	8	5 ^{+0.02} ₀	8
MDHR	-30	M5 x 0.8	4.3	10	5 ^{+0.02} ₀	10
	3	M3 x 0.5	0.88	6	3 ^{+0.02} ₀	6
-15					4 ^{+0.02} ₀	

Vertical mounting

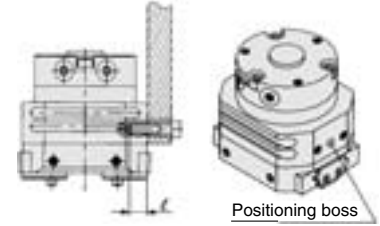

Model	Applicable bolt	Max. tightening torque N·m	Max. screw-in depth \varnothing mm	Positioning boss		
				Bore Depth dmm	Bore Depth hmm	
MHR 2	-10	M3 x 0.5	0.88	6	3 ^{+0.02} ₀	6
	-15				4 ^{+0.02} ₀	
	-20	M4 x 0.7	2.1	8	5 ^{+0.02} ₀	8
MDHR	-30	M5 x 0.8	4.3	10	5 ^{+0.02} ₀	10
	3	M3 x 0.5	0.88	6	3 ^{+0.02} ₀	6
-15					4 ^{+0.02} ₀	

How to Locate Finger and Attachment

- Positioning in the finger's open/close direction**
 Position the finger and the attachment by inserting the finger's pin into the attachment's pin insertion hole. Provide the following pin insertion hole dimensions: shaft-basis fitting dimension C for the open/close direction; slotted hole with relief B for the cross direction.
- Positioning in the finger's cross direction**
 Position the finger and the attachment by placing the finger's width into the attachment's finger insertion groove A.

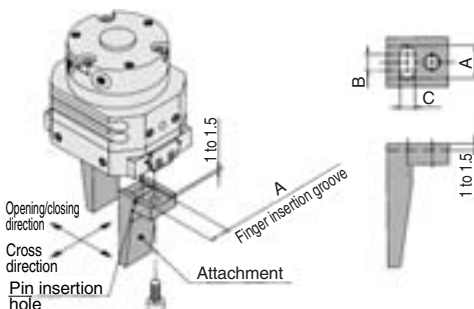

How to Mount the Attachment to the Finger

- To mount the attachment to the finger, make sure to use a wrench to support the attachment so as not to apply undue strain on the finger.
- Refer to the table below for the proper tightening torque on the bolt used for securing the attachment to the finger.

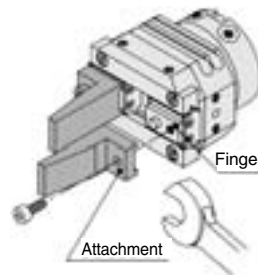

Model	Applicable bolt	Max. tightening torque N·m	
MHR 2	-10	M3 x 0.5	0.59
	-15		
	-20	M4 x 0.7	1.4
MDHR 3	-30	M5 x 0.8	2.8
	-10	M3 x 0.5	0.59

Finger opening/closing speed: MHR2/MHR3

When the finger opening/closing speed is set as the total stroke of 0.2 seconds or more, it may cause the product to stick or completely stop its movement.

SANPUM

为高端制造业提供一流的工业产品

SANPUM

深圳市三浦贸易有限公司

地址：深圳市南山区南海大道海王大厦A座19E

电话：86-755-23881000

传真：86-755-23881777

邮箱：info@sanpum.com



4008 824 824
WWW.SANPUM.COM